

JVC

SERVICE MANUAL

COMPACT COMPONENT SYSTEM

MX-J300

Area Suffix

A	-----	Australia
U	-----	Other Areas
US	-----	Singapore
UT	-----	Taiwan
UP	-----	Korea
UY	-----	Argentina
UZ	-----	Production country mark

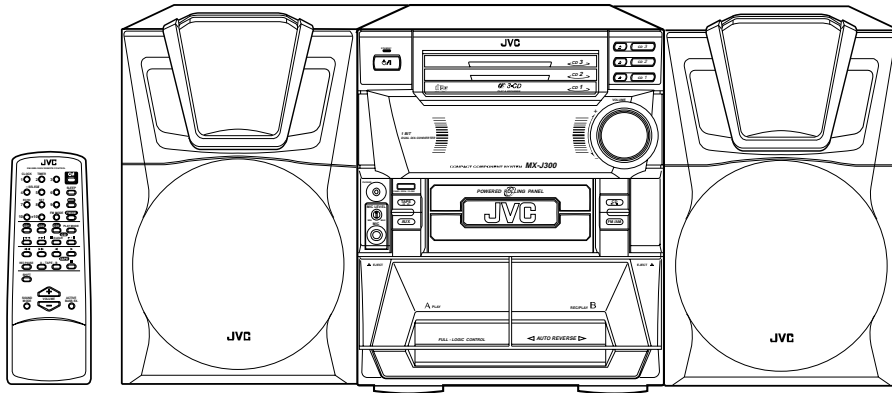

COMPACT
disc
DIGITAL AUDIO

Contents

Safety Precautions	-----	1-2	Flow of functional	
Important for laser products	-----	1-3	operation until TOC read	----- 1-27
Preventing static electricity	-----	1-4	Maintenance of laser pickup	----- 1-28
Disassembly method	-----	1-5	Replacement of laser pickup	----- 1-28
Adjustment method	-----	1-24	Description of major ICs	----- 1-29

Safety Precautions

1. This design of this product contains special hardware and many circuits and components specially for safety purposes. For continued protection, no changes should be made to the original design unless authorized in writing by the manufacturer. Replacement parts must be identical to those used in the original circuits. Services should be performed by qualified personnel only.
2. Alterations of the design or circuitry of the product should not be made. Any design alterations of the product should not be made. Any design alterations or additions will void the manufacturer's warranty and will further relieve the manufacture of responsibility for personal injury or property damage resulting therefrom.
3. Many electrical and mechanical parts in the products have special safety-related characteristics. These characteristics are often not evident from visual inspection nor can the protection afforded by them necessarily be obtained by using replacement components rated for higher voltage, wattage, etc. Replacement parts which have these special safety characteristics are identified in the Parts List of Service Manual. Electrical components having such features are identified by shading on the schematics and by (\triangle) on the Parts List in the Service Manual. The use of a substitute replacement which does not have the same safety characteristics as the recommended replacement parts shown in the Parts List of Service Manual may create shock, fire, or other hazards.
4. The leads in the products are routed and dressed with ties, clamps, tubings, barriers and the like to be separated from live parts, high temperature parts, moving parts and/or sharp edges for the prevention of electric shock and fire hazard. When service is required, the original lead routing and dress should be observed, and it should be confirmed that they have been returned to normal, after re-assembling.

5. Leakage current check (Electrical shock hazard testing)

After re-assembling the product, always perform an isolation check on the exposed metal parts of the product (antenna terminals, knobs, metal cabinet, screw heads, headphone jack, control shafts, etc.) to be sure the product is safe to operate without danger of electrical shock.

Do not use a line isolation transformer during this check.

- Plug the AC line cord directly into the AC outlet. Using a "Leakage Current Tester", measure the leakage current from each exposed metal parts of the cabinet, particularly any exposed metal part having a return path to the chassis, to a known good earth ground. Any leakage current must not exceed 0.5mA AC (r.m.s.)

- Alternate check method

Plug the AC line cord directly into the AC outlet. Use an AC voltmeter having, 1,000 ohms per volt or more sensitivity in the following manner. Connect a 1,500 Ω 10W resistor paralleled by a 0.15 μ F AC-type capacitor between an exposed metal part and a known good earth ground.

Measure the AC voltage across the resistor with the AC voltmeter.

Move the resistor connection to each exposed metal part, particularly any exposed metal part having a return path to the chassis, and measure the AC voltage across the resistor. Now, reverse the plug in the AC outlet and repeat each measurement. voltage measured Any must not exceed 0.75 V AC (r.m.s.). This corresponds to 0.5 mA AC (r.m.s.).

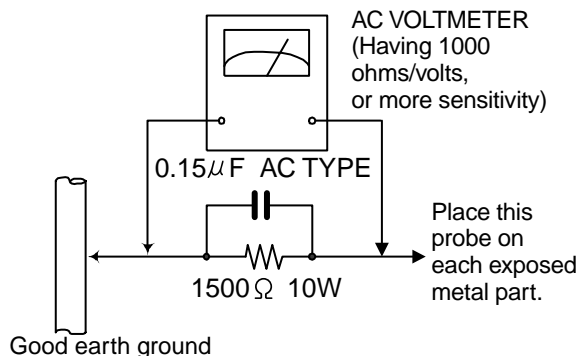

Warning

1. This equipment has been designed and manufactured to meet international safety standards.
2. It is the legal responsibility of the repairer to ensure that these safety standards are maintained.
3. Repairs must be made in accordance with the relevant safety standards.
4. It is essential that safety critical components are replaced by approved parts.
5. If mains voltage selector is provided, check setting for local voltage.

CAUTION Burrs formed during molding may be left over on some parts of the chassis. Therefore, pay attention to such burrs in the case of preforming repair of this system.

Important for laser products

1.CLASS 1 LASER PRODUCT

2.DANGER : Invisible laser radiation when open and interlock failed or defeated. Avoid direct exposure to beam.

3.CAUTION : There are no serviceable parts inside the Laser Unit. Do not disassemble the Laser Unit. Replace the complete Laser Unit if it malfunctions.

4.CAUTION : The compact disc player uses invisible laserradiation and is equipped with safety switches which prevent emission of radiation when the drawer is open and the safety interlocks have failed or are defeated. It is dangerous to defeat the safety switches.

5.CAUTION : If safety switches malfunction, the laser is able to function.

6.CAUTION : Use of controls, adjustments or performance of procedures other than those specified herein may result in hazardous radiation exposure.

CAUTION Please use enough caution not to see the beam directly or touch it in case of an adjustment or operation check.

VARNING : Osynlig laserstrålning är denna del är öppnad och spårren är urkopplad. Betrakta ej strålen.

VARO : Avattaessa ja suojalukitus ohitettaessa olet alttiina näkymättömälle lasersäteilylle. Älä katso säteeseen.

ADVARSEL : Usynlig laserstrålning ved åbning , når sikkerhedsafbrydere er ude af funktion. Undgå udsættelse for stråling.

ADVARSEL : Usynlig laserstrålning ved åbning, når sikkerhedsbryteren er avslott. unngå utsettelse for stråling.

REPRODUCTION AND POSITION OF LABELS

WARNING LABEL

DANGER : Invisible laser radiation when open and interlock or defeated.
AVOID DIRECT EXPOSURE TO BEAM (e)

VARO : Avattaessa ja suojalukitus ohitettaessa olet alttiina näkymättömälle lasersäteilylle. Älä katso säteeseen. (d)

VARNING : Osynlig laserstrålning är denna del är öppnad och spårren är urkopplad. Betrakta ej strålen. (s)

ADVARSEL : Usynlig laserstrålning ved åbning , når sikkerhedsafbrydere er ude af funktion. Undgå udsættelse for stråling. (f)

**CLASS 1
LASER PRODUCT**

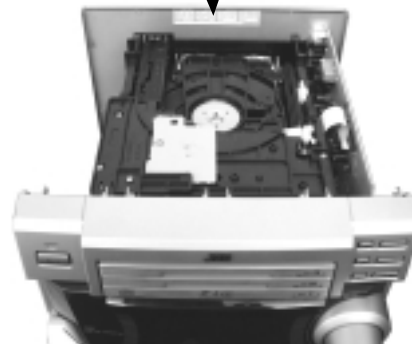
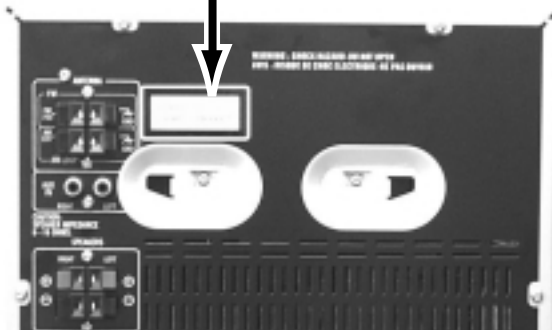

Preventing static electricity

1. Grounding to prevent damage by static electricity

Electrostatic discharge (ESD), which occurs when static electricity stored in the body, fabric, etc. is discharged, can destroy the laser diode in the traverse unit (optical pickup). Take care to prevent this when performing repairs.

2. About the earth processing for the destruction prevention by static electricity

In the equipment which uses optical pick-up (laser diode), optical pick-up is destroyed by the static electricity of the work environment.

Be careful to use proper grounding in the area where repairs are being performed.

2-1 Ground the workbench

Ground the workbench by laying conductive material (such as a conductive sheet) or an iron plate over it before placing the traverse unit (optical pickup) on it.

2-2 Ground yourself

Use an anti-static wrist strap to release any static electricity built up in your body.

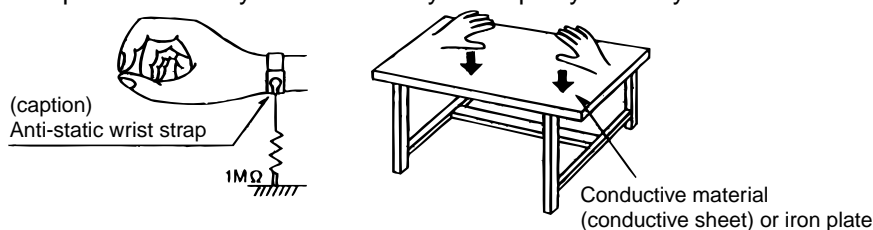

3. Handling the optical pickup

1. In order to maintain quality during transport and before installation, both sides of the laser diode on the replacement optical pickup are shorted. After replacement, return the shorted parts to their original condition. (Refer to the text.)

2. Do not use a tester to check the condition of the laser diode in the optical pickup. The tester's internal power source can easily destroy the laser diode.

4. Handling the traverse unit (optical pickup)

1. Do not subject the traverse unit (optical pickup) to strong shocks, as it is a sensitive, complex unit.

2. Cut off the shorted part of the flexible cable using nippers, etc. after replacing the optical pickup. For specific details, refer to the replacement procedure in the text. Remove the anti-static pin when replacing the traverse unit. Be careful not to take too long a time when attaching it to the connector.

3. Handle the flexible cable carefully as it may break when subjected to strong force.

4. It is not possible to adjust the semi-fixed resistor that adjusts the laser power. Do not turn it

Attention when traverse unit is decomposed

***Please refer to "Disassembly method" in the text for pick-up and how to detach the CD traverse mechanism.**

1. Remove the disk stopper and T. bracket on the CD changer mechanism assembly.

2. Disconnect the harness from connector on the CD motor board.

3. CD traverse unit is put up as shown in Fig.1.

4. Solder is put up before the card wire is removed from connector CN601 on the CD servo control board as shown in Fig. 2.

(When the wire is removed without putting up solder, the CD pick-up assembly might destroy.)

5. Please remove solder after connecting the card wire with CN601 when you install picking up in the substrate.

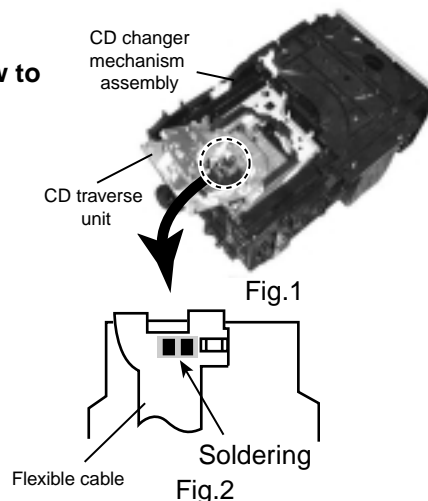

Disassembly method

<Main body>

■ Removing the metal cover

(See Fig.1 to 3)

1. Remove the six screws **A** attaching the metal cover on the back of the body.
2. Remove the two screws **B** on both sides of the body.
3. Remove the metal cover from the body while lifting up the rear part of the metal cover.

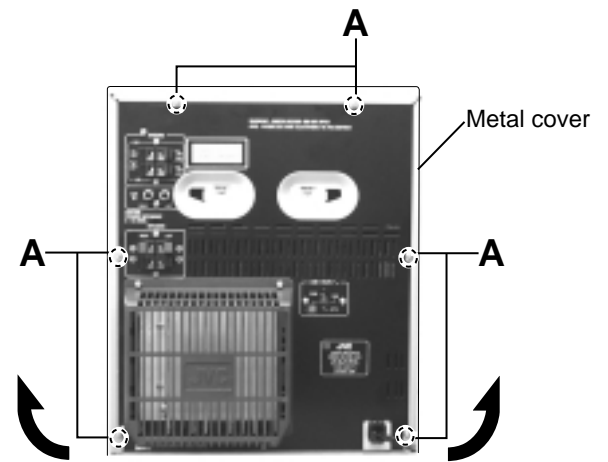

Fig.1

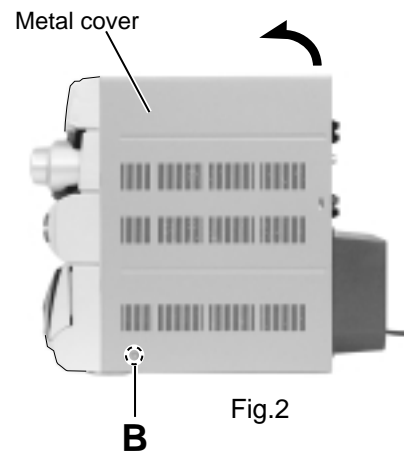

Fig.2

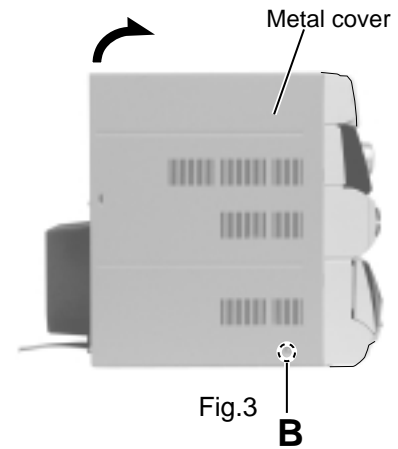
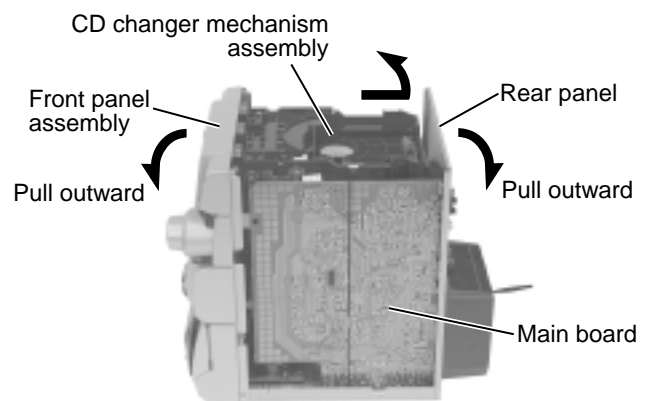
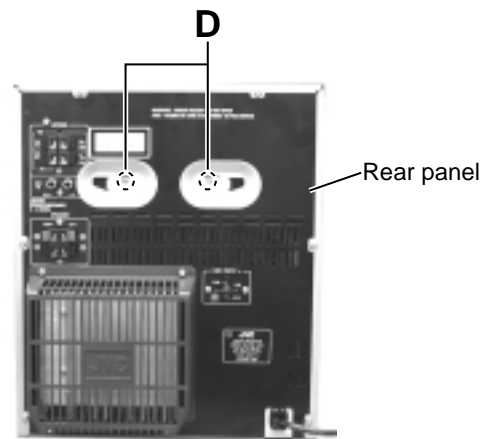
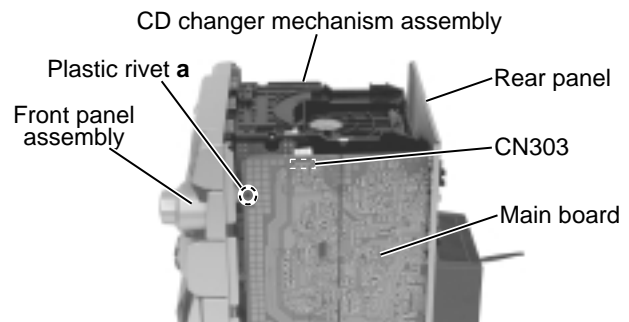
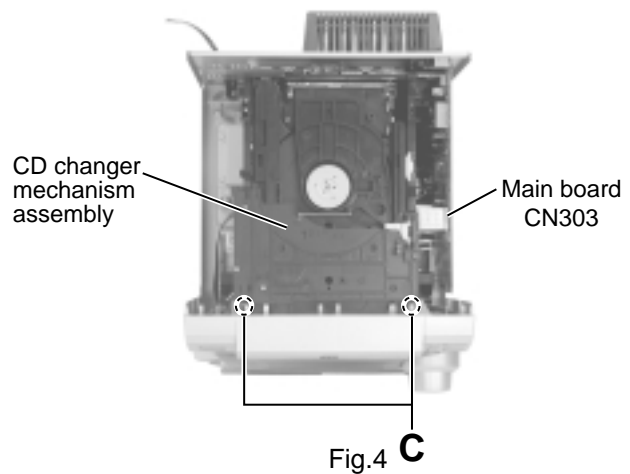

Fig.3

■ Removing the CD changer mechanism assembly (See Fig.4 to 7)

- Prior to performing the following procedures, remove the metal cover.
1. Remove the two screws **C** attaching the CD changer mechanism assembly on the top of the body.
 2. Disconnect the card wire from connector CN303 on top of the main board.
 3. Remove the plastic rivet **a** fixing the main board to the front panel assembly on the left side of the body.
 4. Remove the two screws **D** from the rear panel.
 5. Detach upward the rear part of the CD changer mechanism assembly while pulling the front panel assembly and the rear panel outward, then pull out the front part backward and upward.



■ Removing the front panel assembly (See Fig.8 to 12)

- Prior to performing the following procedures, remove the metal cover and the CD changer mechanism assembly.

1. Disconnect the card wires from connector CN301, CN304, CN305 and the harness from CN302, CN307 on the inside of the main board.
2. Remove the one screw **E** attaching the earth wire.
3. Turn over the body and remove the two screws **F**.
4. Release the joint **b** on the bottom of the body and the joint **c** and **d** on both sides of the body using a screwdriver, and detach the front panel assembly toward the front.

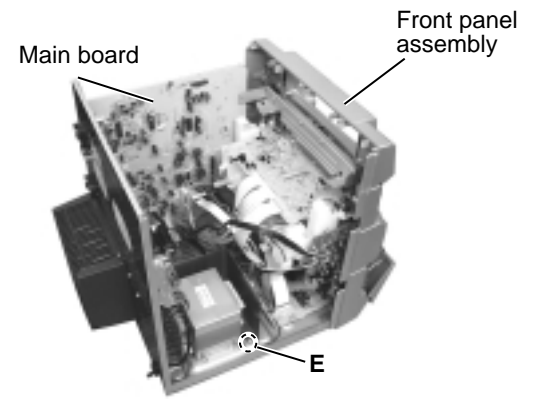

Fig.8

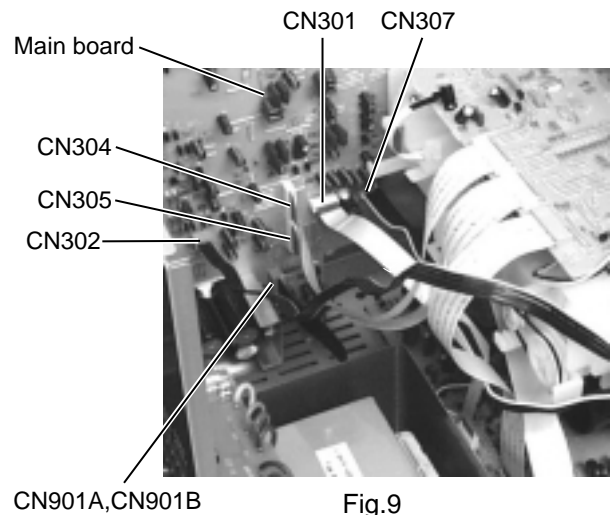

Fig.9

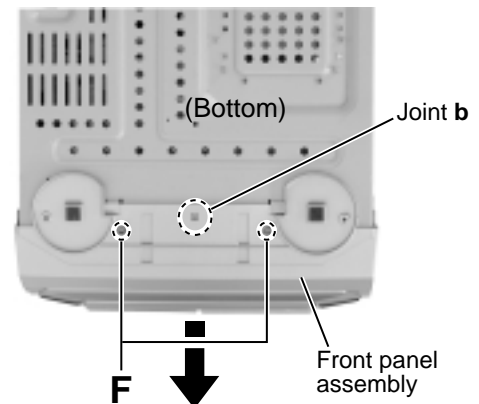

Fig.10

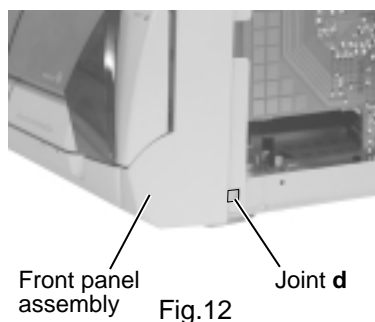

Fig.12

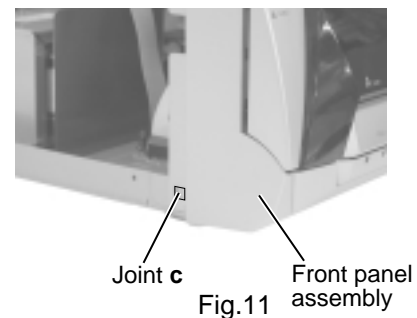

Fig.11

■Removing the rear cover, the rear panel and the voltage selector

(See Fig.13 to 16)

- Prior to performing the following procedures, remove the metal cover and the CD changer mechanism assembly.
- It is not necessary to remove the front panel assembly.

1. Remove the two screws **G** and the rear cover on the back of the body.
2. Remove the four screws **H** and the six screws **I** attaching the main board and the heat sink to the rear panel.
3. Remove the screw **J** attaching the rear panel to the chassis base.
4. Remove the two screws **J'** attaching the rear panel to the voltage selector. (Except A/UP)
5. Release the lower two joints **e** and **f** on both sides of the rear panel using a screwdriver and detach the rear panel backwards.

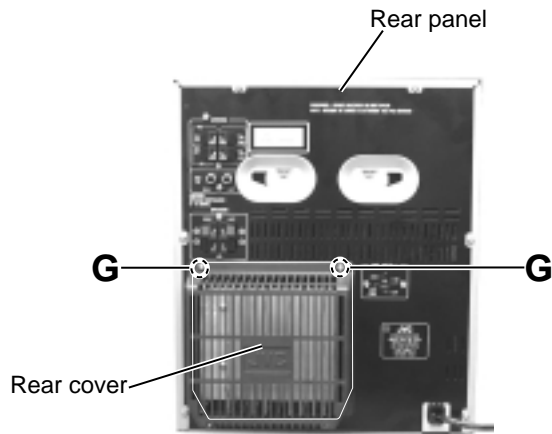

Fig.13

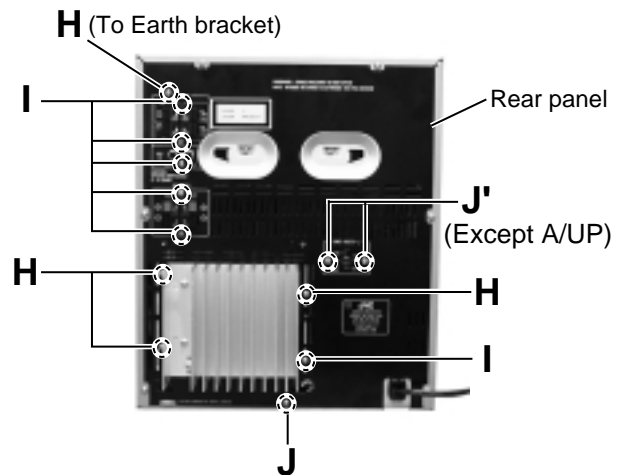

Fig.14

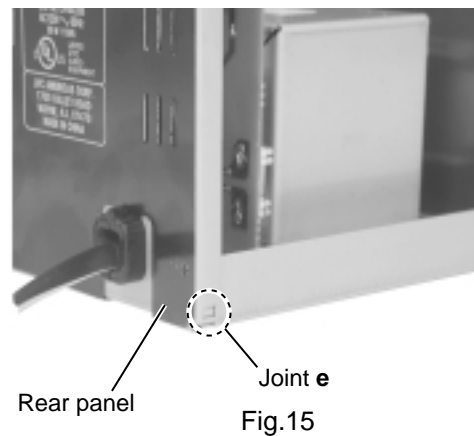

Fig.15

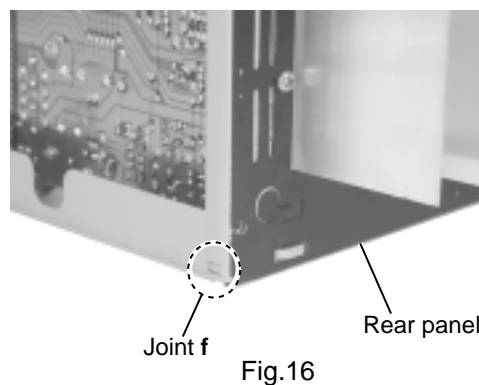

Fig.16

■ Removing the main board

(See Fig.17 to 20)

- Prior to performing the following procedures, remove the metal cover, the CD changer mechanism assembly and the rear cover, rear panel. It is not necessary to remove the front panel assembly.

1. Disconnect the card wires from connector CN301, CN304, CN305 and the harnesses from CN302, CN307, CN901A and CN901B on the inside of the main board.
2. From the right side of the body, remove the screw **K** attaching the main board to the chassis base.

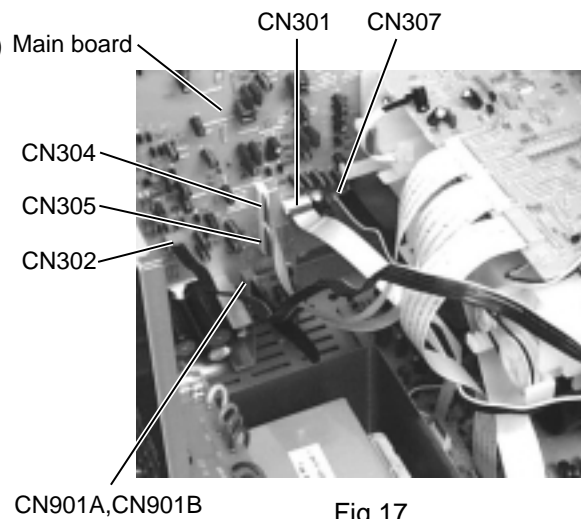

Fig.17

~To remove the heat sink from the main board~

Prior to performing the following procedure, remove the rear panel.

1. Remove the two screws **L** and the screw **M** attaching the heat sink to the main board. Remove the IC bracket 1 and 2 on the back of the heat sink.
2. Pull out the heatsink toward you.

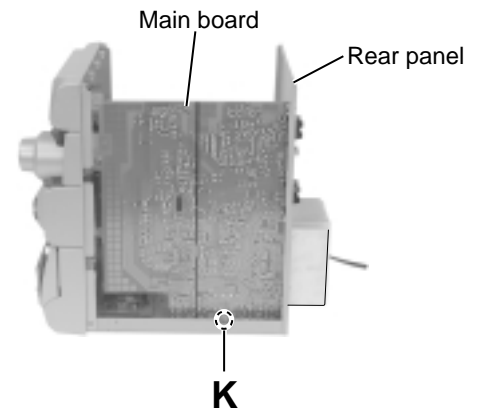

Fig.18

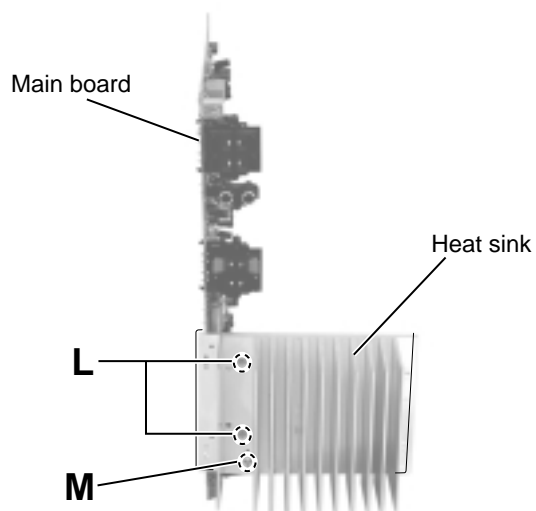

Fig.19

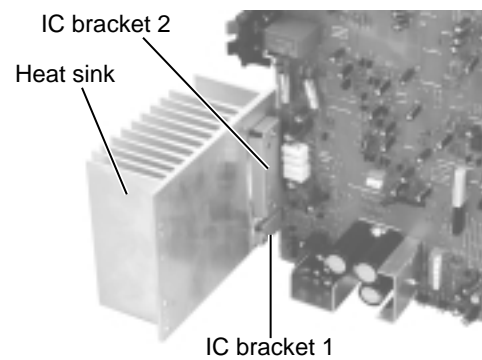
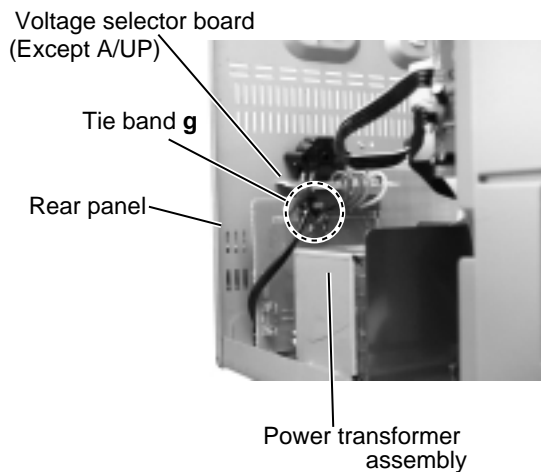
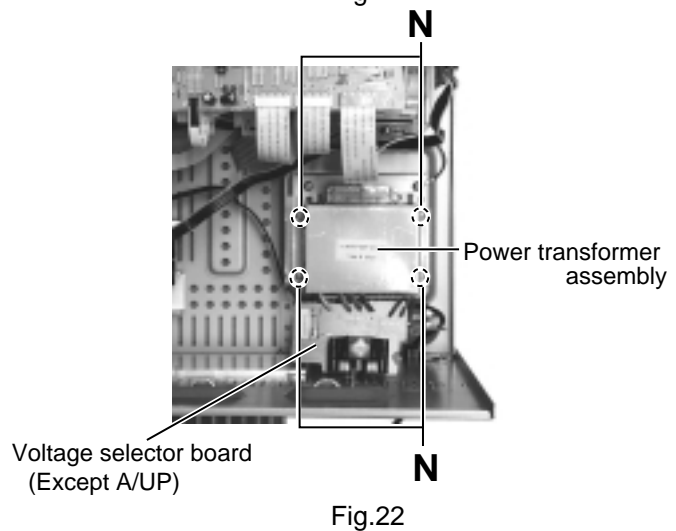
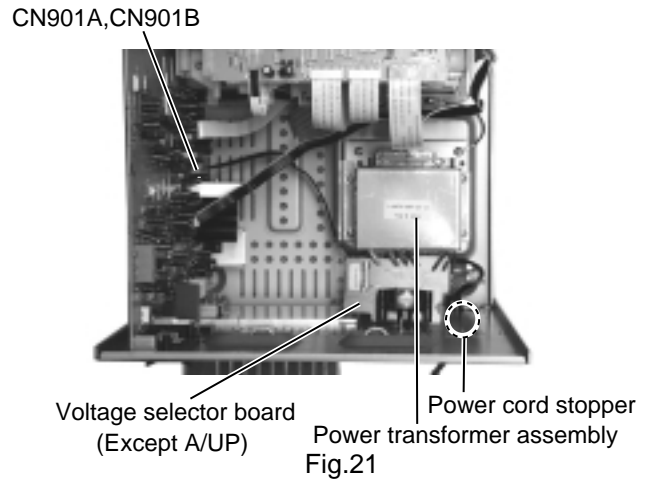

Fig.20

■Removing the power transformer assembly (See Fig.21 to 23)

- Prior to performing the following procedure, remove the metal cover and the CD changer mechanism assembly.
1. Disconnect the harness from connector CN901A and CN901B on the inside of the main board.
 2. Cut off the tie band **g** of the power transformer assembly and unsolder the power cord. (Make sure to bundle the wires after repair.)
 3. Remove the four screws **N** attaching the power transformer assembly.
- When removing the power transformer assembly with the power cord, remove the rear panel and pull out the power cord stopper from the bottom chassis upward.



<Front panel assembly>

■ **Removing the headphone & MIC board (Except A) / headphone board(Only A) (Fig.24 and Fig.25)**

- Prior to performing the following procedure, remove the metal cover, the CD changer mechanism assembly and the front panel assembly.

<Ver. U/US/UT/UP/UY/UZ>

1. Remove the two screws **O** & **O'** attaching the headphone & MIC board.
2. Remove the MIC LEVEL knob from front side.

<Ver. A>

1. Remove the screw **O** attaching the headphone board.

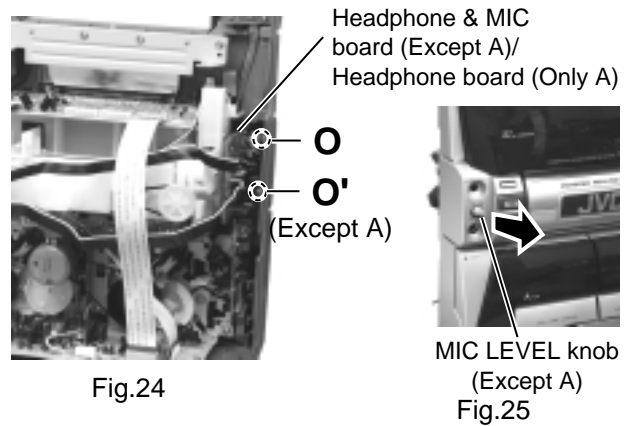

■ **Removing the cassette mechanism assembly (Fig.26)**

- Prior to performing the following procedure, remove the metal cover, the CD changer mechanism assembly and the front panel assembly.

1. Disconnect the card wire from connector CN352 on the cassette amplifier board.
2. Remove the six screws **P** attaching the cassette mechanism assembly.
3. Detach the cassette mechanism assembly toward you.

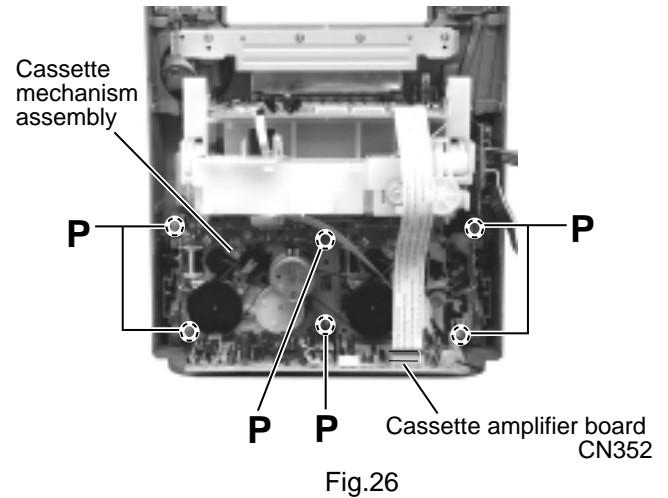

■ **Removing the cassette amplifier board (See Fig.27 and 28)**

- Prior to performing the following procedure, remove the cassette mechanism assembly.

1. Disconnect the card wire from connector CN353 on the cassette amplifier board.

ATTENTION: When reconnecting the card wire, put it pass through under the harness **h** on the DC motor (The Fig.27 shows the details).

2. Unsolder the soldering **i** on the flexible wire for the cassette amplifier board head at the bottom of the cassette mechanism assembly.
3. Remove the four screws **Q** attaching the cassette amplifier board on the bottom of the cassette mechanism assembly.

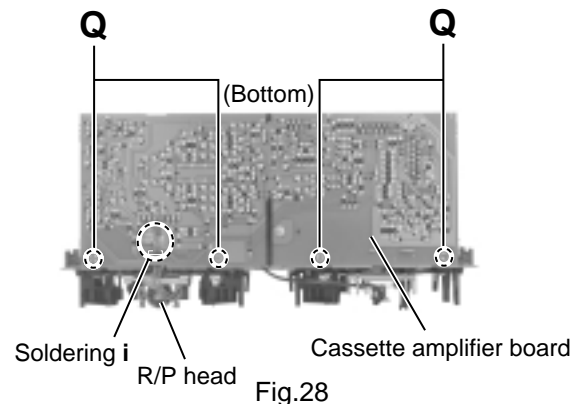
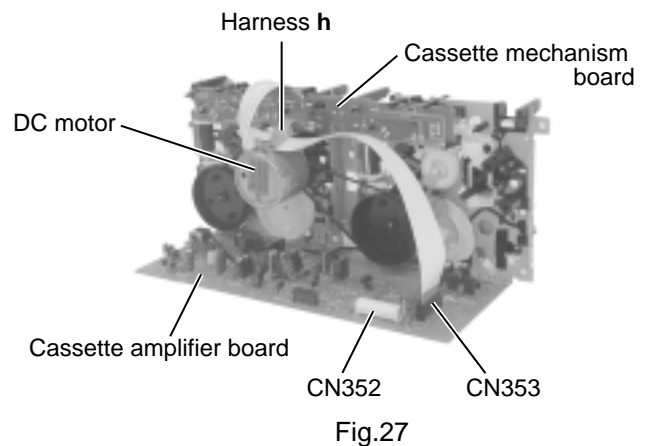

**■ Removing the rolling panel assembly
(See Fig.29 to 31)**

- Prior to performing the following procedure, remove the metal cover, the CD changer mechanism assembly and the front panel assembly.
 - Remove the headphone & MIC board (Except A) / headphone board (Only A).
1. Disconnect the card wire from connector CN704 and the harness from CN706, CN707 and CN708 on the display board over the rolling panel.
 2. Remove the four screws **R** attaching the bracket.
 3. Remove the four screws **S** attaching the rolling panel assembly.
 4. Pull out the rolling panel assembly.

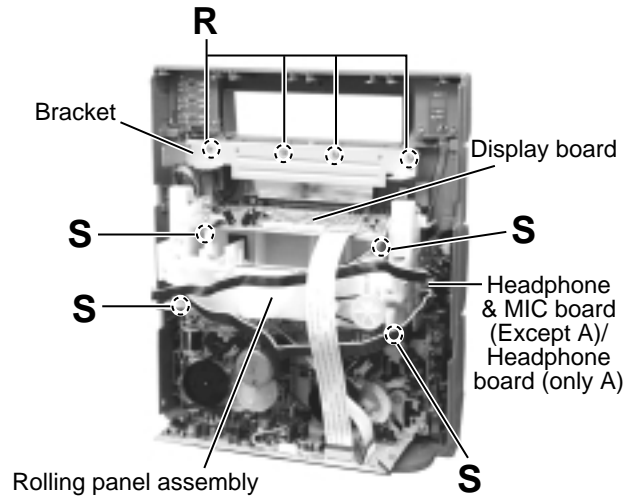

Fig.29

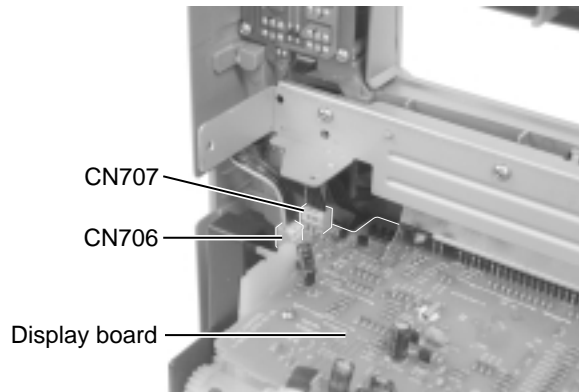

Fig.30

■ Removing the display board (See Fig.32)

- Prior to performing the following procedure, remove the rolling panel assembly.
1. Disconnect the card wire from connector CN705 and the harness from CN703 on the display board.
 2. Remove the two screws **T** attaching the display board.
 3. Pull out the display board upward.

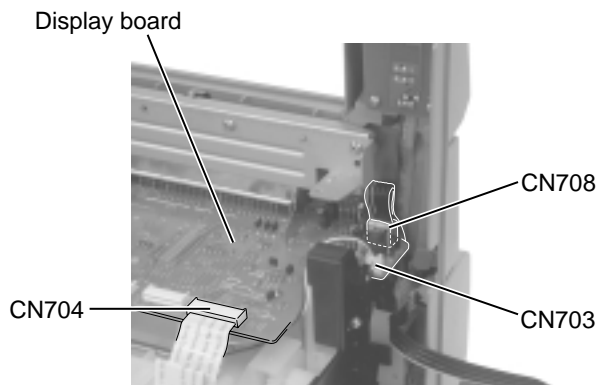

Fig.31

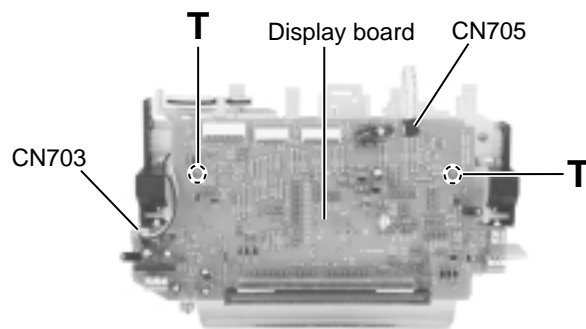

Fig.32

■Removing each board in the front panel assembly (See Fig.33 to 35)

- Prior to performing the following procedure, remove the rolling panel assembly.

~Function board 1~ (Fig.33 and 35)

1. Remove the two screws **U** attaching the function board 1. Detach the function board downwards while releasing it from the part **k**.
2. Unsolder FW1002 on the function board 1 and disconnect the harness extending from the power switch board.

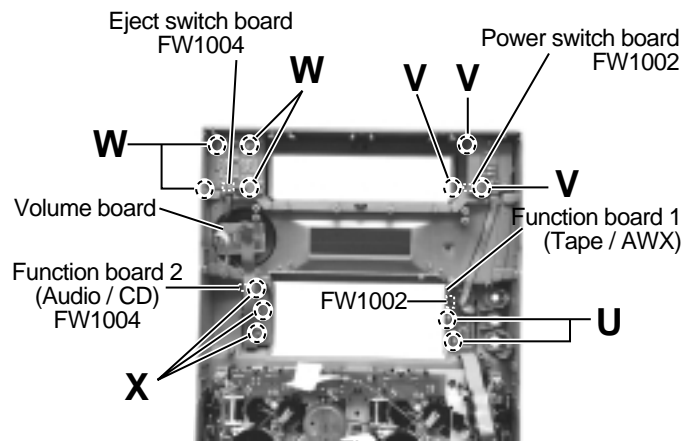

Fig.33

~Function board 2~ (Fig.33)

1. Remove the three screws **X** attaching the function board 2.
2. Unsolder FW1004 on the function board 2 and disconnect the harness extending from the eject switch board.

~Volume board~ (Fig.33 and 34)

1. Pull out the volume knob on the front of the front panel assembly and remove the nut attaching the volume board.
2. Unhook the two hooks **j** on the back of the front panel assembly and detach the volume board.

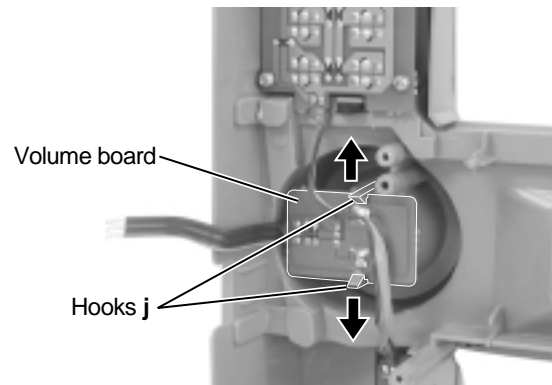

Fig.34

~Eject switch board ~ (Fig.35)

1. Remove the four screws **W** attaching the eject switch board.
2. Unsolder FW1004 on the eject switch board and disconnect the harness extending from the function board 2.

~Power switch board~ (Fig.33 and 35)

1. Remove the three screws **V** attaching the power switch board.
2. Unsolder FW1002 on the power switch board and disconnect the harness extending from the function board 1.

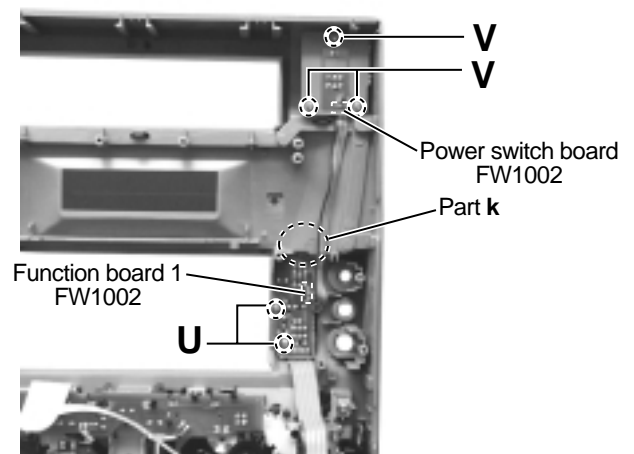

Fig.35

<Rolling panel assembly>

- Prior to performing the following procedures, remove the metal cover the CD changer mechanism assembly, the front panel assembly and the rolling panel assembly.
It is not necessary to remove the display board.

**■ Removing the multi-control assembly
(See Fig.36 to 38)**

1. Remove the two screws **Y** on both sides of the multi-control assembly.
2. Disconnect the card wire from connector CN705 on the display board.
3. Pull outwards the joints **I** on both sides and detach the multi-control assembly toward the front.

**■ Removing the multi-control board
(See Fig.39 to 41)**

- Prior to performing the following procedure, remove the multi-control assembly.

1. Remove the six screws **Z** attaching the cover and the bracket.
2. Release the hooks **m** on both sides of the panel holder attaching the bracket and pull out the panel holders outward.
Detach the multi-control board with the cover and the bracket attached.
3. Remove the two screws **A** attaching the multi-control board.

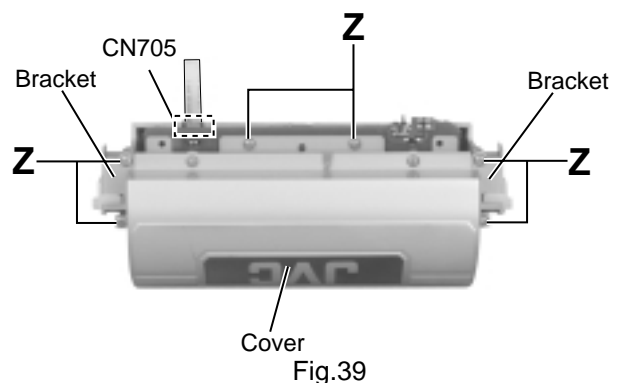
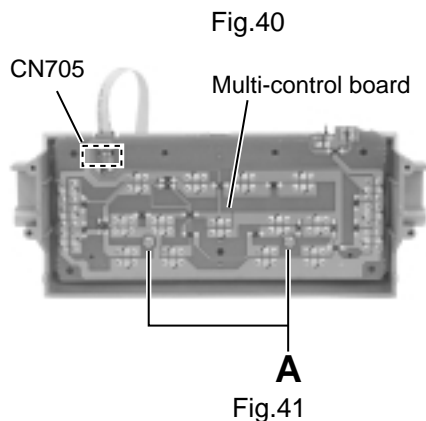
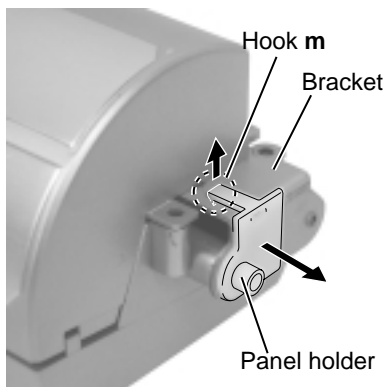
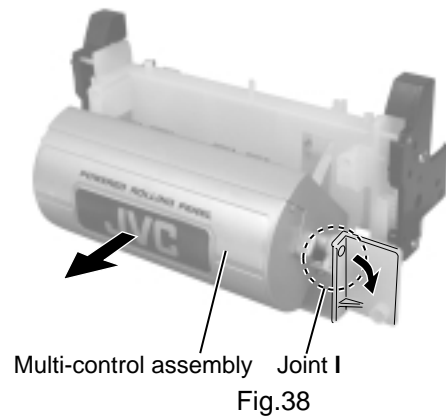
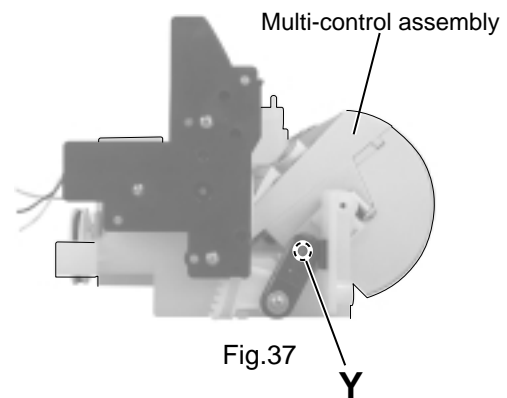
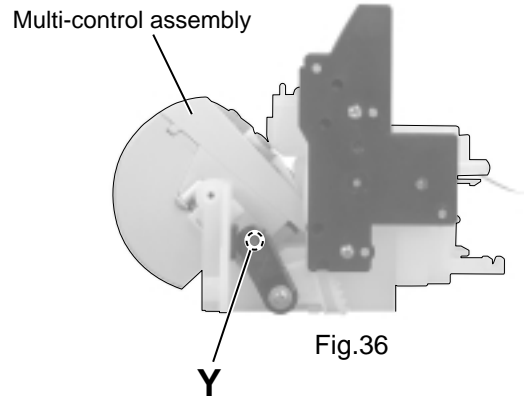

■ Removing the drive motor assembly (See Fig.42 and 43)

- Prior to performing the following procedures, remove the display board.
1. Remove the two screws **B** attaching the motor bracket, then detach the motor leads from the fixing plate **n**.
 2. Remove the two screws **C** attaching the shaft bracket.
 3. Remove the motor belt.
 4. Pull the part **o** on each side of the shaft assembly outwards and detach the shaft assembly upward.
 5. Detach the drive motor assembly upward.

Caution :

When remove the flat wire from the connector CN705, please pay attention not to crease the flat wire. When creased, the flat wire may be broken in the operation hundred of times.

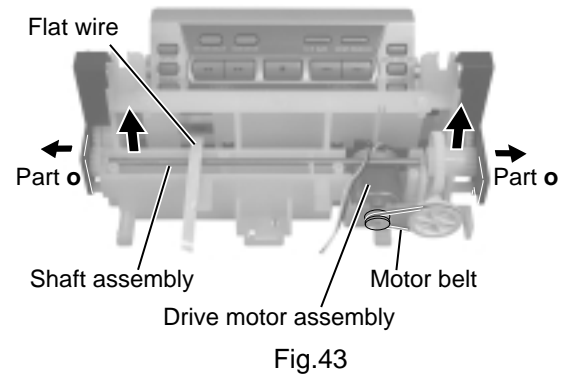
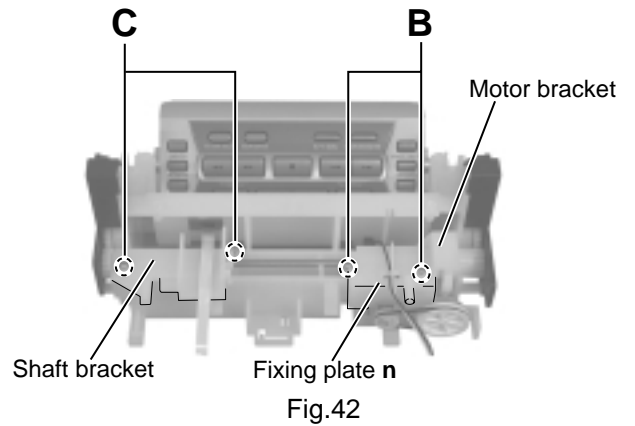

«CD Changer Mechanism Type:VC3 Section»

■ Removing the CD Servo control board
(See Fig.1)

- 1.Remove the metal cover.
- 2.Remove the CD changer mechanism assembly.
- 3.From bottom side the CD changer mechanism assembly, remove the two screws **A** retaining the CD servo control board.
- 4.Absorb the four soldered positions "a" of the right and left motors with a soldering absorber.
- 5.Pull out the earth wire on the CD changer mechanism assembly.
- 6.The two screws **B** is removed and C.B.holder is detached.
- 7.Disconnect the connector CN854 on the CD servo control board.
- 8.Disconnect the card wire CN601 and the connector CN801 on the CD servo control board.

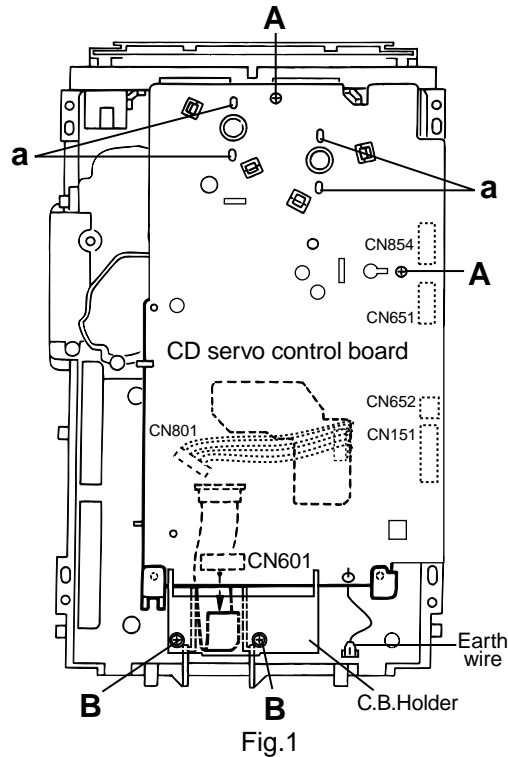

■ Removing the CD tray assembly
(See Fig.2~4)

1. Remove the front panel assembly. (See Fig.2~4)
2. Remove the CD changer mechanism assembly.
3. Remove the CD Servo control board.
4. Remove the screw **C** retaining the lod stopper. (See Fig.3)
5. From the T.bracket section "b" and clamber base section "c", remove both of the edges fixing the rod(See Fig.2 and 3).
6. Remove the screw **D** retaining the disc stopper (See Fig.3).
7. Remove the three screws **E** retaining the T.bracket (See Fig.3).
8. Remove the screw **F** retaining the clamber assembly (See Fig.3).
9. From the left side face of the chassis assembly, remove the one screw **G** retaining both of the return spring and lock lever(See Fig. 4).
10. By removing the pawl at the section "d" fixing the return spring, dismount the return spring(See Fig.4).
11. Remove the three lock levers(See Fig.4).

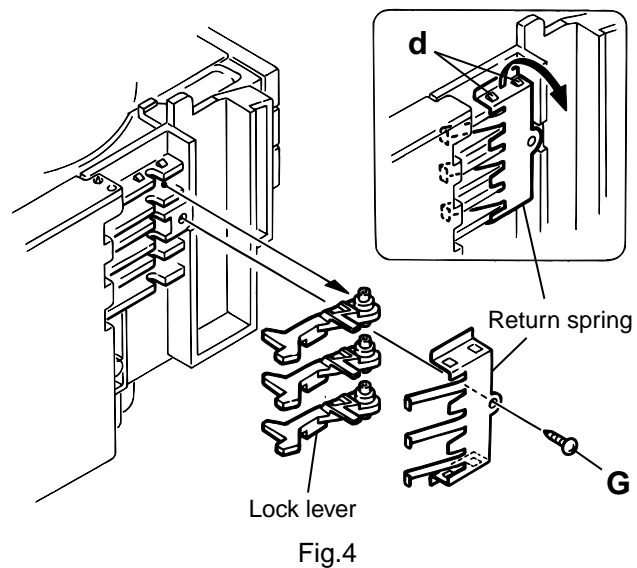
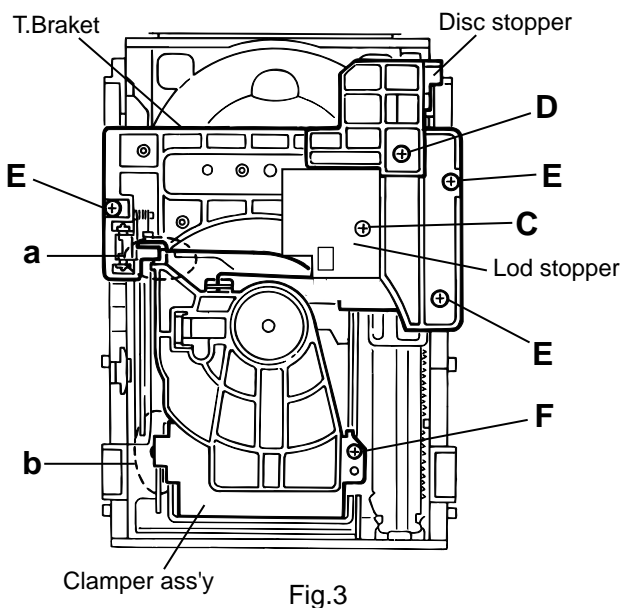
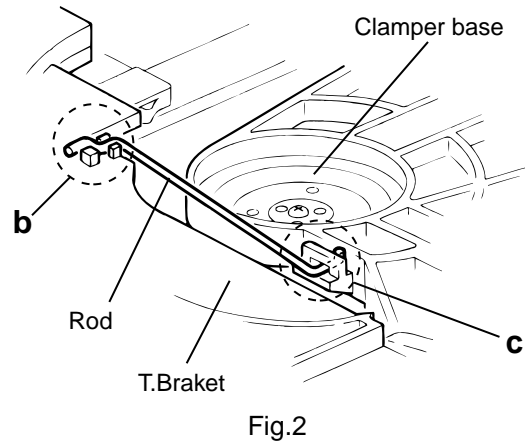

11. Check whether the lifter unit stopper has been caught into the hole at the section "e" of CD tray assembly as shown in Fig.5.
12. Make sure that the driver unit elevator is positioned as shown in Fig.6 from the second or fifth hole on the left side face of the CD changer mechanism assembly.

[Caution] In case the driver unit elevator is not at above position, set the elevator to the position as shown in Fig.7 by manually turning the pulley gear as shown in Fig.8.

13. Manually turn the motor pulley in the clockwise direction until the lifter unit stopper is lowered from the section "e" of CD tray assembly(See Fig.8).
14. Pull out all of the three stages of CD tray assembly in the arrow direction "f" until these stages stop (See Fig.6).
15. At the position where the CD tray assembly has stopped, pull out the CD tray assembly while pressing the two pawls "g and g' " on the back side of CD tray assembly(See Fig.9). In this case, it is easy to pull out the assembly when it is pulled out first from the stage CD tray assembly.

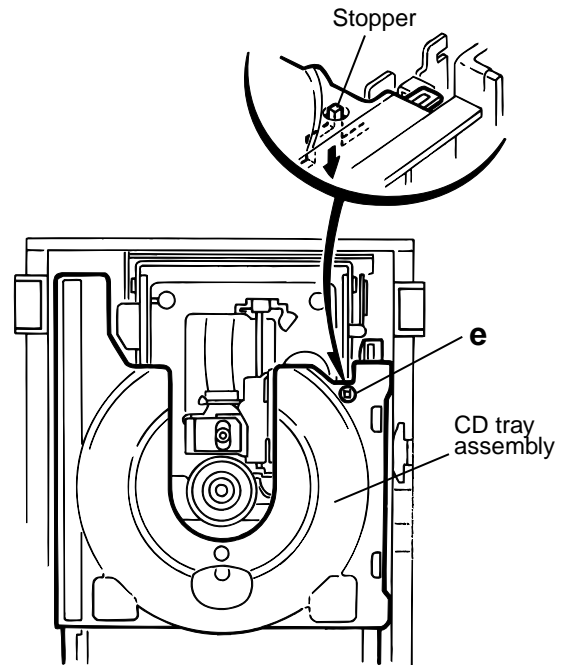

Fig.5

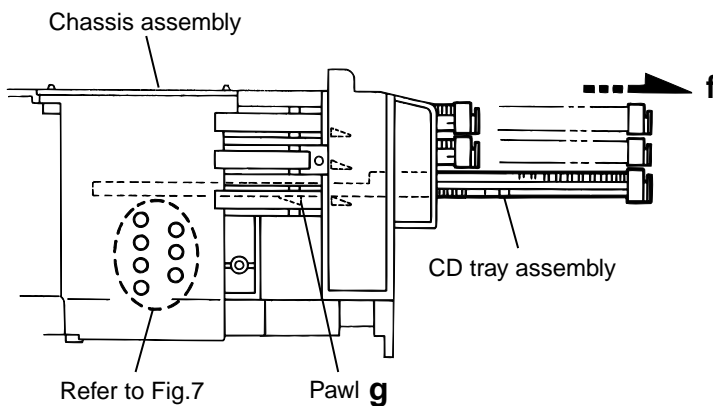

Fig.6

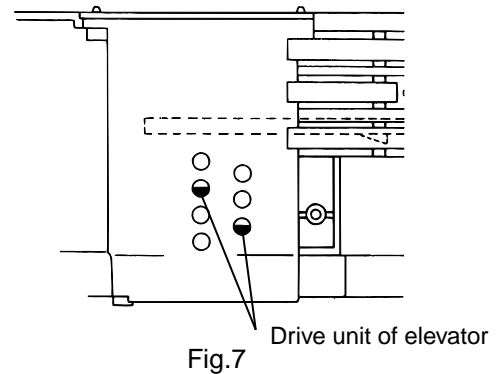

Fig.7

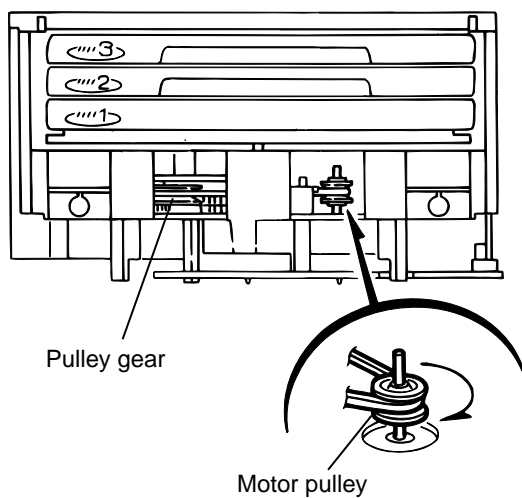
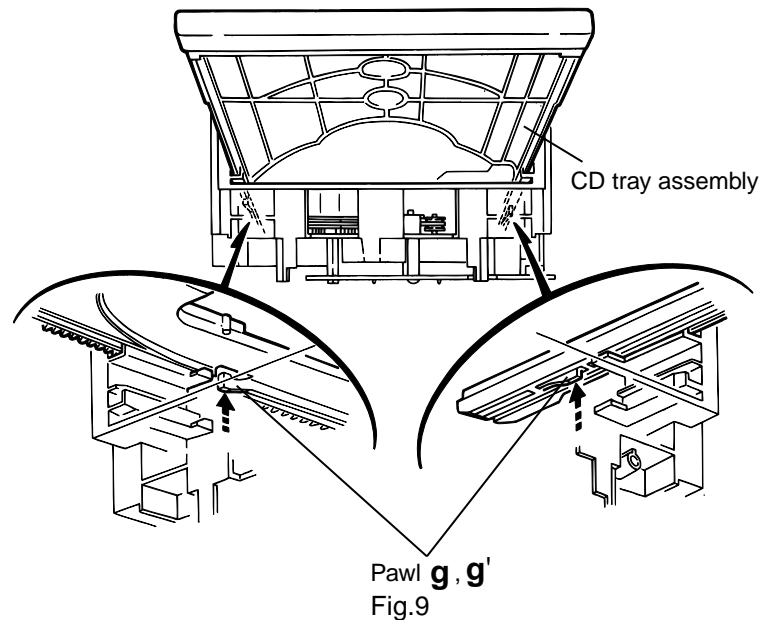

Fig.8



Pawl g, g'
Fig.9

■ Removing the CD loading mechanism assembly(See Fig.10)

1. While turning the cams R1 and R2 assembly in the arrow direction "h",align the shaft "i" of the CD loading mechanism assembly to the position shown in Fig.10.
2. Remove the four screws H retaining the CD loading mechanism assembly.

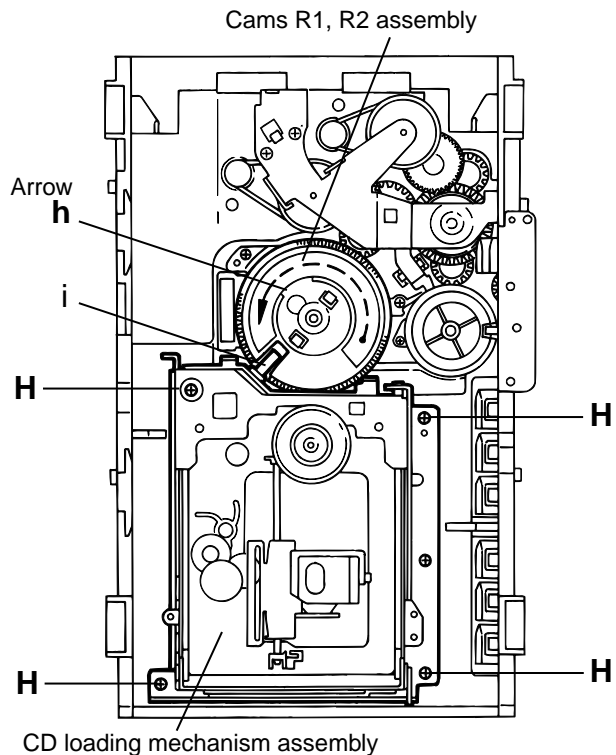

Fig.10

■ Removing the CD traverse mechanism (See Fig.11 and 12)

1. For dismounting only the CD traverse mechanism without removing the CD loading mechanism assembly, align the shaft "j" of the CD loading mechanism assembly to the position shown Fig.11 while turning the cam R1 and R2 assembly in the arrow direction "k" .
2. By raising the CD loading mechanism assembly in the arrow direction "l", remove the assembly from the lifter unit

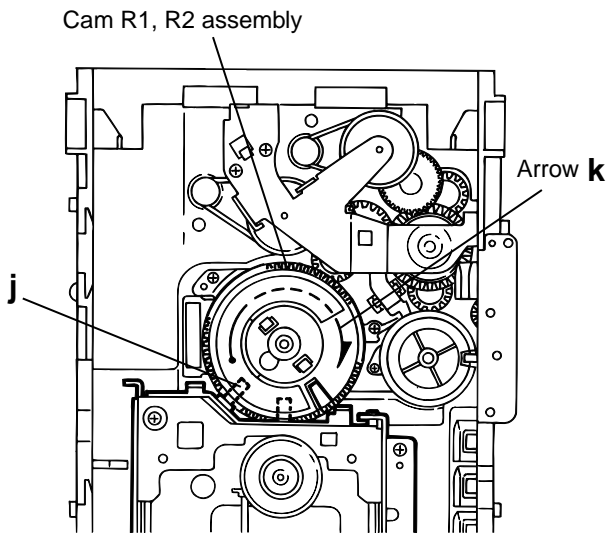

Fig.11

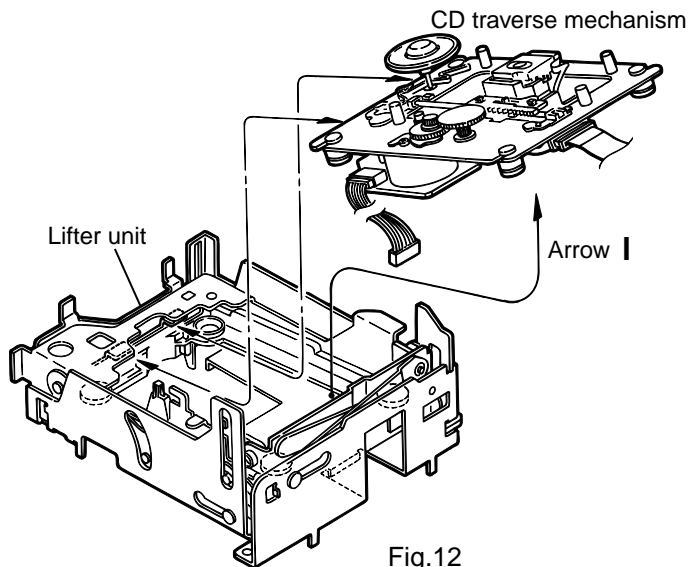

Fig.12

■ Removing the CD pick unit (See Fig.13)

1. Move the cam gear in the arrow direction "m" . Then, the CD pickup unit will be moved in the arrow direction "n" .
2. According to the above step, shift the CD pickup unit to the center position.
3. While pressing the stopper retaining the shaft in the arrow direction "o" , pull out the shaft in the arrow direction "p" .
4. After dismounting the shaft from the CD pickup unit, remove the CD pickup unit

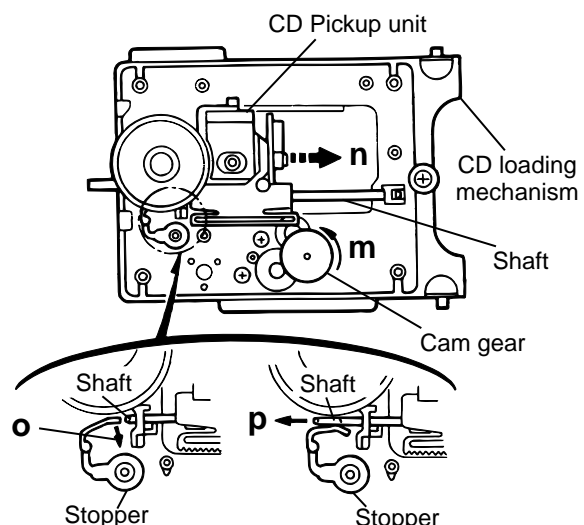

Fig.13

■ Removing the cam unit (See Fig.14 ~17)

1. Remove the CD loading mechanism assembly.
2. While turning the cam gear "q", align the pawl "r" position of the drive unit to the notch position(Fig.15) on the cam gear "q".
3. Pull out the drive unit and cylinder gear(See Fig.16).
4. While turning the cam gear "q", align the pawl "s" position of the select lever to the notch position(Fig.17) on the cam gear "q".
5. Remove the four screws **J** retaining the cam unit(cam gear "q" and cams R1/R2 assembly)(See Fig.17).

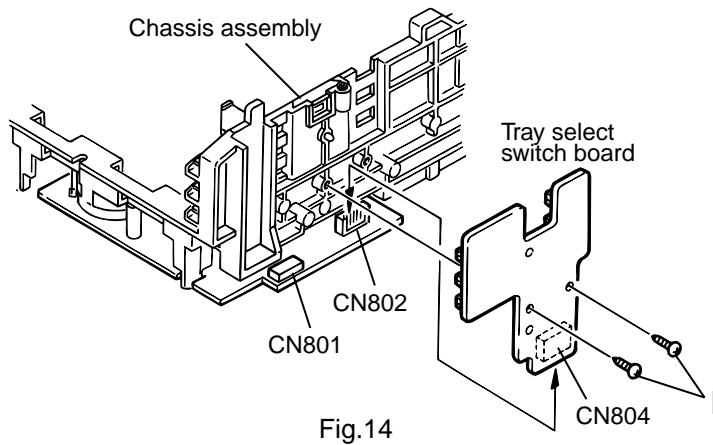

Fig.14

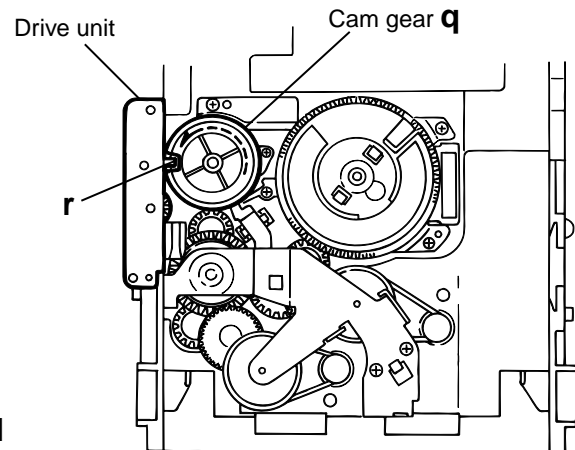

Fig.15

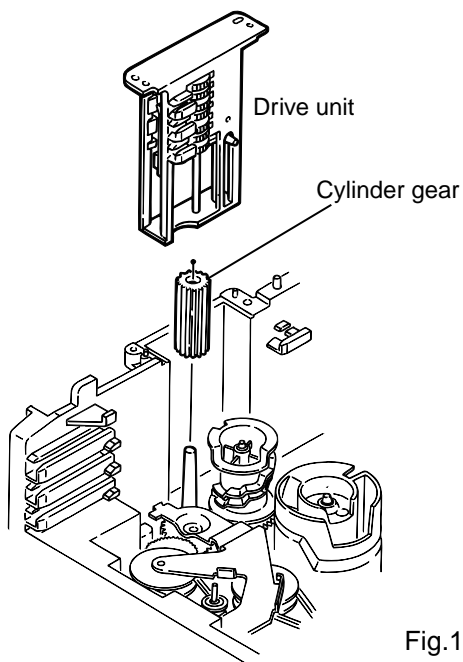

Fig.16

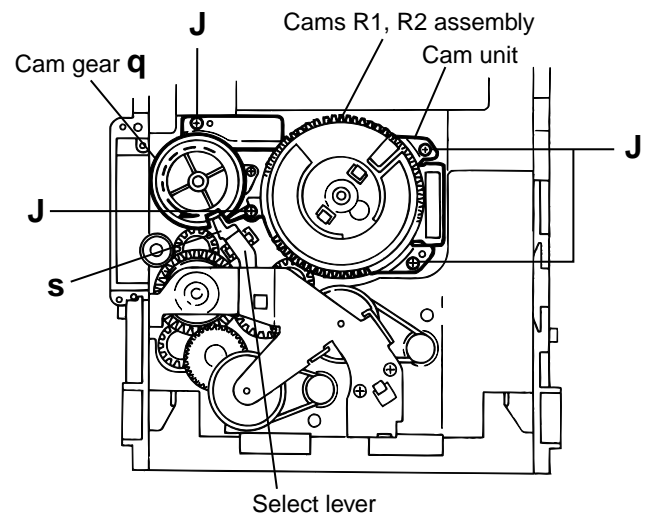

Fig.17

**■ Removing the actuator motor and belt
(See Fig.18~21)**

1. Remove the two screws **K** retaining the gear bracket
(See Fig.18).
2. While pressing the pawl "t" fixing the gear bracket in the arrow direction, remove the gear bracket
(See Fig.18).
3. From the notch "u" section" on the chassis assembly fixing the edge of gear bracket, remove and take out the gear bracket(See Fig. 19).
4. Remove the belts respectively from the right and left actuator motor pulleys and pulley gears(See Fig. 18).
5. After turning over the chassis assembly, remove the actuator motor while spreading the four pawls "v" fixing the right and left actuator motors in the arrow direction(See Fig. 20).

[Note] When the chassis assembly is turned over under the conditions wherein the gear bracket and belt have been removed, then the pulley gear as well as the gear, etc. constituting the gear unit can possibly be separated to pieces. In such a case, assemble these parts by referring to the assembly and configuration diagram in Fig. 21.

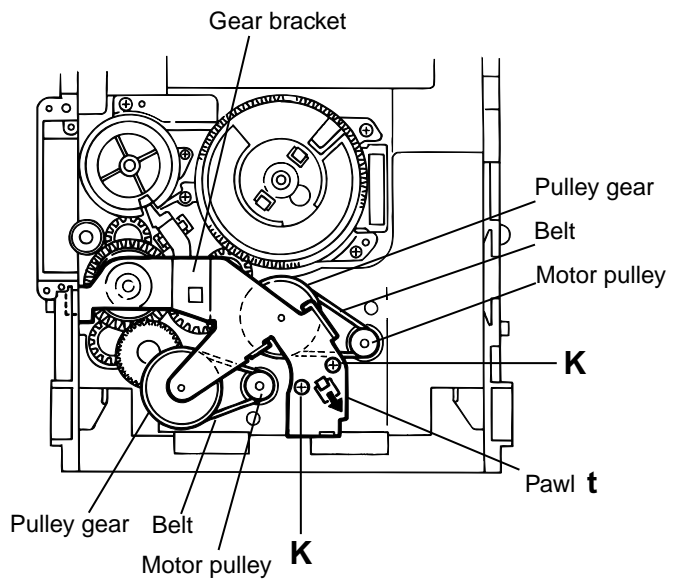

Fig.18

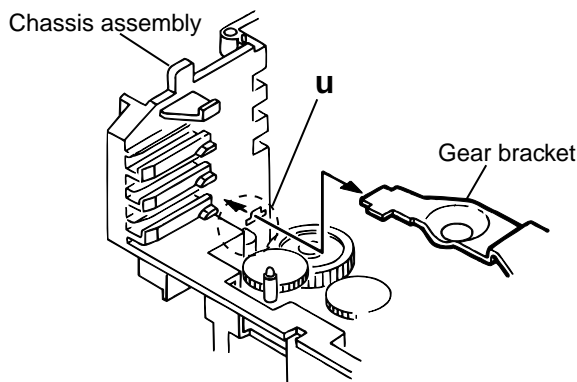

Fig.19

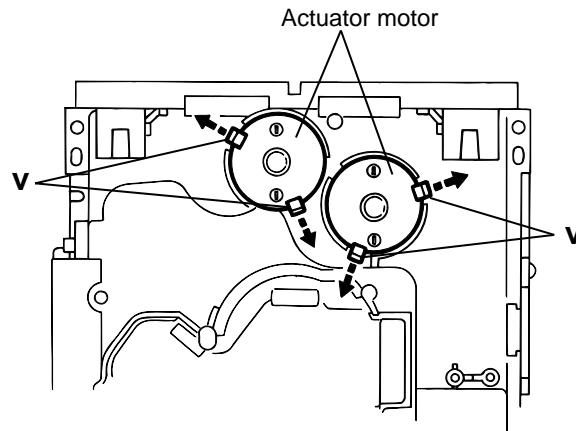

Fig.20

Assembly and Configuration Diagram

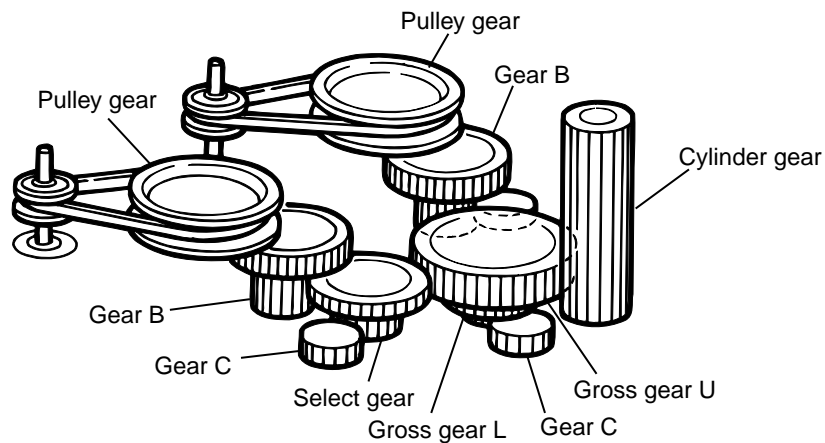

Fig.21

■ Removing the cams R1/R2 assembly and cam gear q(See Fig.22)

1. Remove the slit washer fixing the cams R1 and R2 assembly.
2. By removing the two pawls "w" fixing the cam R1, separate R2 from R1.
3. Remove the slit washer fixing the cam gear "q".
4. Pull out the cam gear "q" from the C.G. base assembly.

■ Removing the C.G. base assembly (See Fig.22 and 23)

Remove the three screws **L** retaining the C.G. base assembly.

[Caution] To reassemble the cylinder gear, etc.with the cam unit (cam gear and cans R1/R2 assembly), gear unit and drive unit, align the position of the pawl "x" on the drive unit to that of the notch on the cam gear "q". Then, make sure that the gear unit is engaged by turning the cam gear "q" (See Fig. 23).

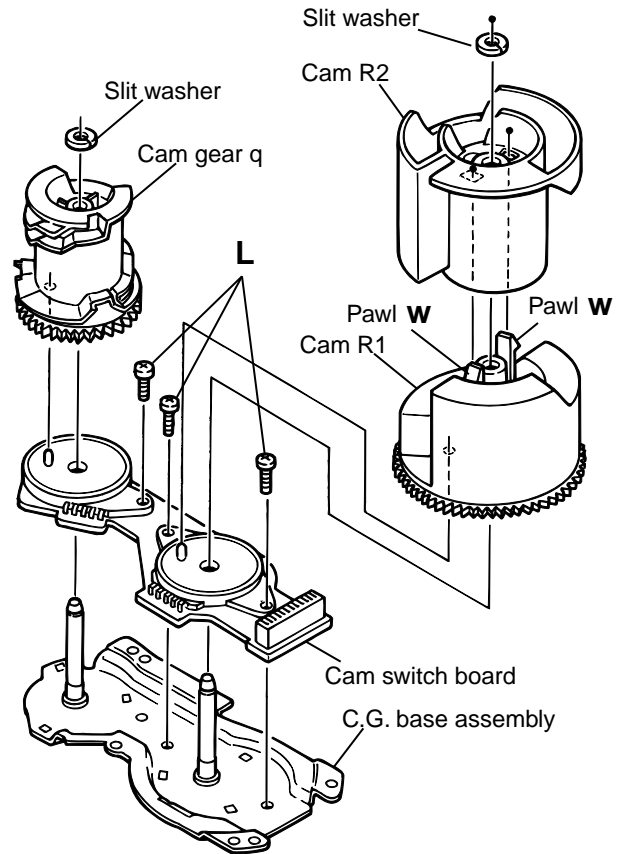

Fig.22

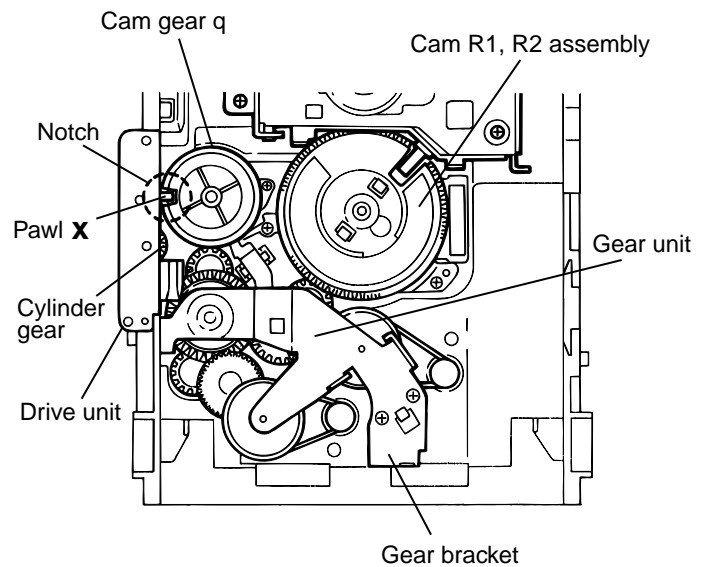

Fig.23

< **Cassette mechanism section** >

- Prior to performing the following procedures, remove the metal cover the CD changer mechanism assembly, the front panel assembly and cassette mechanism assembly.

■ **Removing the R/P head assembly**
(See Fig.1to2)

1. Unsolder the head wire from the cassette mechanism board.
2. Remove the two screws **A** retaining the R/P head assembly.

Refer to the figure for soldering

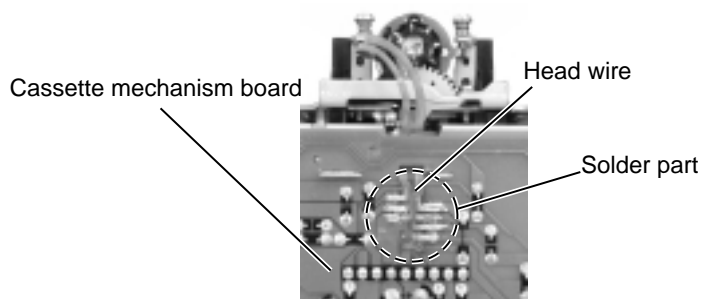

Fig.2

■ **Removing the P/B head assembly**
(See Fig.3)

1. Loosen the screw **B** attaching the P/B head assembly.
2. Remove the screws **C** retaining the P/B head assembly.

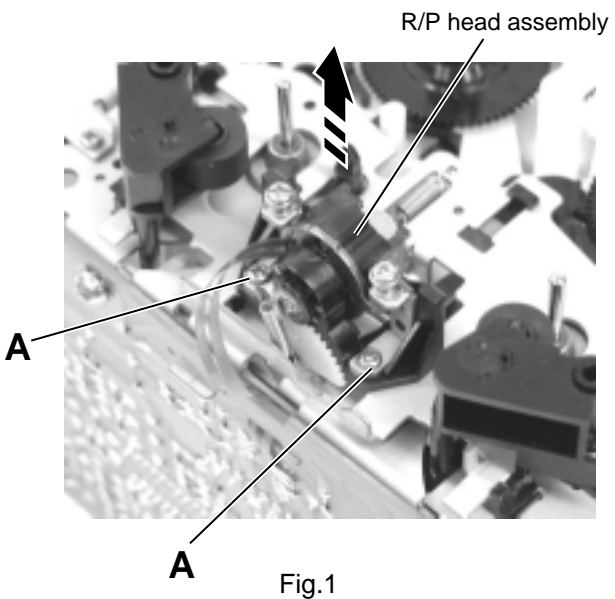

Fig.1

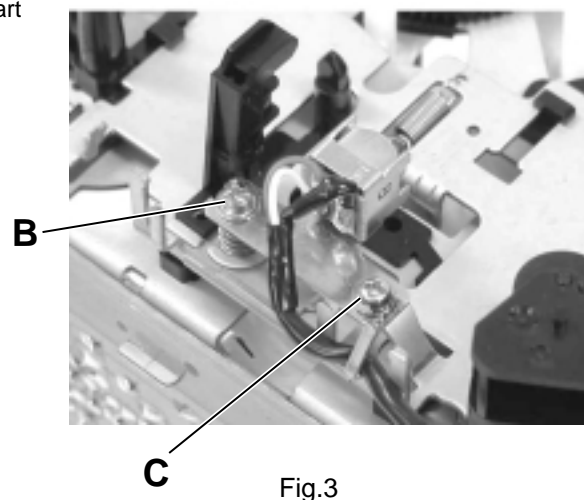

Fig.3

■ **Removing the Pinch roller assembly**
(See Fig.4)

1. Pull the tab **a** outward and remove the pinch roller upward.

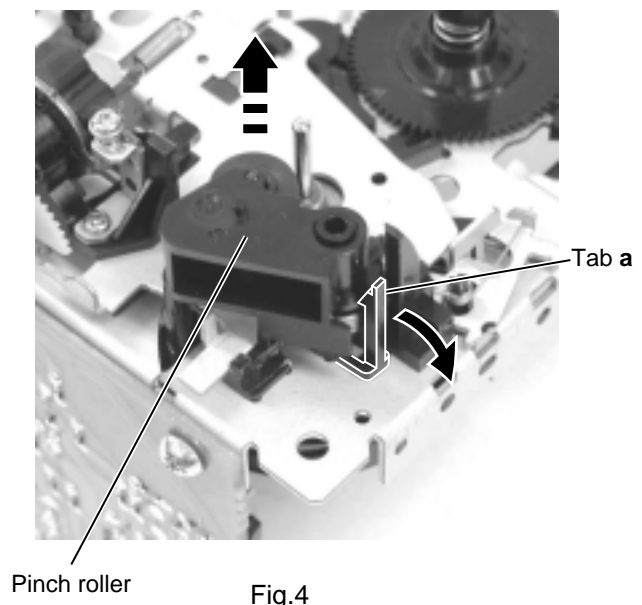

Fig.4

■ Removing the Capstan motor

(See Fig.5to7)

1. Remove the two screws **D** attaching the capstan motor.
2. Unsolder the motor wire.

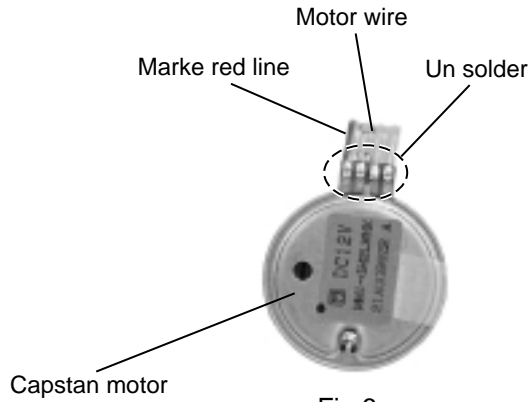

Fig.6

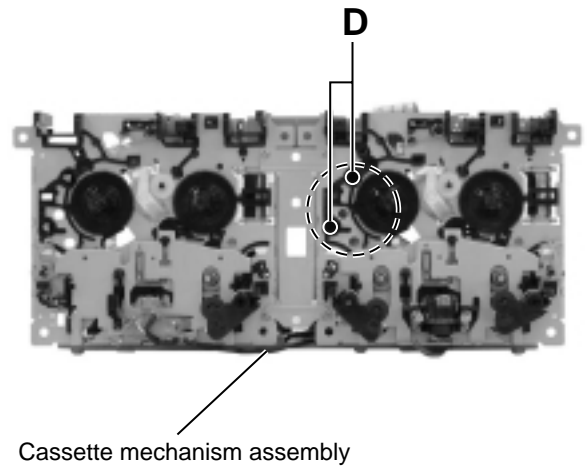

Fig.5

■ Removing the Capstan belt (See Fig.7)

1. Remove the capstan motor.
2. Remove the capstan belt.

ATTENTION: Do not stain the belt with grease.

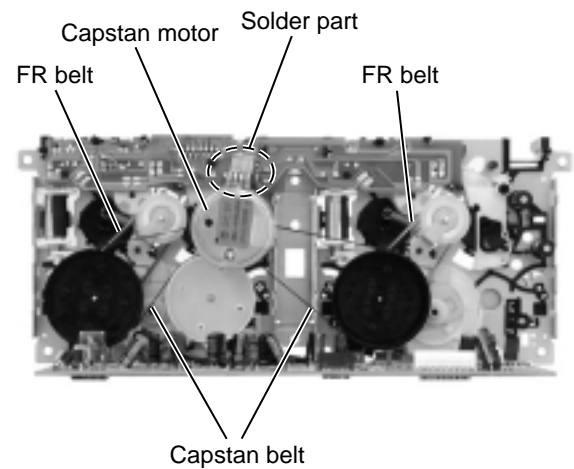

Fig.7

Adjustment method

Measurement instruments required for adjustment

1. Low frequency oscillator,
This oscillator should have a capacity to output 0dB to 600ohm at an oscillation frequency of 50Hz-20kHz.
2. Attenuator impedance : 600ohm
3. Electronic voltmeter
4. Frequency counter
5. Wow flutter meter
6. Test tape
VT712 : For Tape speed and wow flutter (3kHz)
VT703 : For Head angle(10kHz),Play back frequency characteristics(1kHz),and dubbing frequency characteristics(63,1,10kHz)
Because of frequency-mixed tape with 63,1k,10k and 14kHz(250nWb/m -24dB).
Use this tape together with a filter.
7. Blank tape
TAPE I : AC-225, TAPE II : AC-514
8. Torque gauge : For play and back tension
Forward ; TW2111A, Reverse ; TW2121A
Fast Forward and Rewind ; TW2231A
9. Test disc
: CTS-1000(12cm),GRG-1211(8cm)
10. Jitter meter

Measurement conditions

Power supply voltage
AC110/127/220/230-240V(50/60Hz) : U/US/UT/UY
AC220V(60Hz) : UP
AC240V(50Hz) : A

Measurement
output terminal : Speaker out
: TP101(Measuring for TUNER/DECK/CD)
: Dummy load 6ohm

Radio input signal

AM modulation frequency : 400Hz
Modulation factor : 30%
FM modulation frequency : 400Hz
Frequency displacement : 22.5kHz

Frequency Range

AM 531kHz~1710kHz (Except A)
522kHz~1629kHz (Only A)
FM 87.5MHz~108MHz

Standard measurement positions of volume and switch

Power : Standby (Light STANDBY Indicator)
S,A,BASS : OFF
Sound mode : OFF
Main VOL. : 0 Minimum
Traverse mecha set position : Disc 1
Mic MIX VOL : MAX (Except A)
ECHO : OFF (Except A)

Precautions for measurement

1. Apply 30pF and 33kohm to the IF sweeper output side and 0.082 μ F and 100kohm in series to the sweeper input side.
2. The IF sweeper output level should be made as low as possible within the adjustable range.
3. Since the IF sweeper is a fixed device, there is no need to adjust this sweeper.
4. Since a ceramic oscillator is used, there is no need to perform any MPX adjustment.
5. Since a fixed coil is used, there is no need to adjust the FM tracking.
6. The input and output earth systems are separated.
In case of simultaneously measuring the voltage in both of the input and output systems with an electronic voltmeter for two channels, therefore, the earth should be connected particularly.
7. In the case of BTL connection amplifier, the minus terminal of speaker is not for earthing. Therefore, be sure not to connect any other earth terminal to this terminal. This system is of an OTL system.

■ Arrangement of adjusting positions

Cassette mechanism section (Mechanism A section)

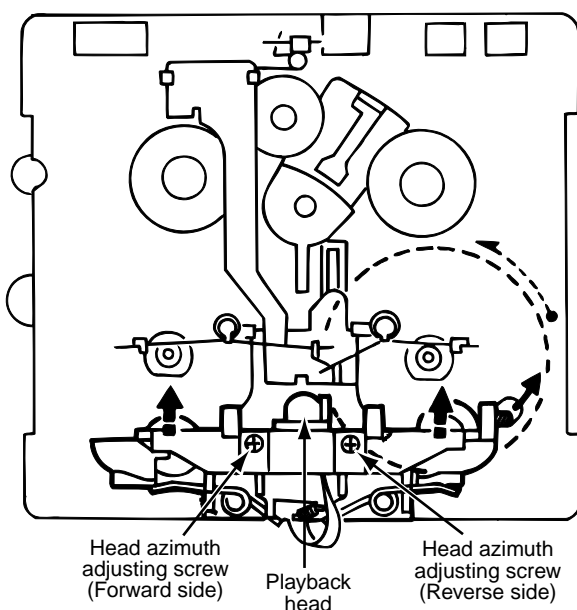

Cassette mechanism section (Back side)

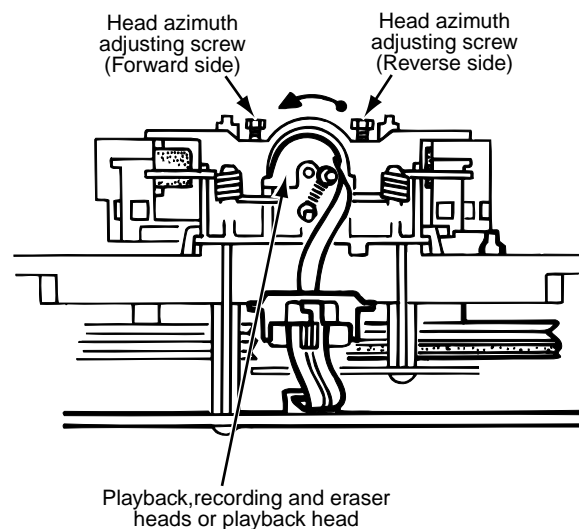

■ Tape recorder section

Items	Measurement conditions	Measurement method	Standard values	Adjusting positions
Confirmation of head angle	Test tape VT703(10kHz) Measurement output terminal :Speaker terminal Speaker R (Load resistor:3ohm) :Headphone terminal	1.Playback the test tape VT703(10kHz). 2.With the playback mechanism or recording & playback mechanism, adjust the head azimuth screw so that the forward and reverse output levels become maximum.After adjustment,lock the head azimuth at least by half a turn. 3.In either case,this adjustment should be performed in both the forward and reverse directions with the head azimuth screw.	Maximum output	Adjust the head azimuth screw only when the head has been changed.
Confirmation of tape speed	Test tape :VT712(3kHz) Measurement output terminal :Headphone terminal	<Constant speed> Adjust the volume inside of capstan motor1 so that the frequency counter reading becomes 3,000Hz \pm 60Hz when playing back the test tape VT712(3kHz) with the playback mechanism or playback and recording mechanism after ending forward winding of the tape.	Tape speed of decks (A and B) :3,000Hz \pm 60Hz	Volume Inside of capstan motor

■ Reference values for confirmation items

Items	Measurement conditions	Measurement method	Standard values	Adjusting positions
Double tape speed	Test tape :VT712 (3kHz) Measurement output terminal :Speaker terminal Speaker R (Load resistance:3ohm) measurement output terminal :Headphone terminal	After setting to the double speed motor, confirm that the frequency counter reading becomes 4,800+400/-300Hz when the test tape VT712 (3kHz) has been play back with the playback mechanism.	4,800+400/-300Hz	Playback mechanism side
Difference between the forward and reverse speed. P.mecha and R/P mecha speed		When the test tape VT712(3kHz) has been played back with the playback mechanism or recording and playback mechanism at the beginning of forward winding, the frequency counter reading of the difference between both of the mechanisms should be 6.0Hz or less.	60Hz or less	Both the playback and recording & playback mechanism
Wow & flutter	Test tape :VT712 (3kHz) Measurement output terminal :Headphone terminal	When the test tape VT712(3kHz) has been played back with the playback mechanism or recording and playback mechanism at the beginning of forward winding the frequency counter reading of wow & flutter should be 0.25% or less(WRMS).	with in 0.25% JIS(WTD)	Both the playback and recording & playback mechanism

■ Reference values for electrical function confirmation items

Items	Measurement conditions	Measurement method	Standard values	Adjusting positions
Recording bias frequency	*Recording and playback side forward or reverse *Test tape :TYP II AC-514 *Measurement terminal BIAS TP on P.C.board	1.While changing over to and from BIAS 1 and 2, confirm that the frequency is changed. 2.With the recording and playback mechanism. load the test tape (AC-514 to TYP II),and set the mechanism to the recording and pausing conditions in advance. 3.Confirm that the BIAS TP frequency on the P.C.board is 100kHz±6kHz.	100kHz +9kHz -7kHz	
Eraser current (Reference value)	*Recording and playback side forward or reverse *Recording mode *Test tape :AC-514 and AC-225 Measurement terminal Both of the eraser head	1.With the recording and playback mechanism, load the test tapes(AC-514 to TYP II and AC-225 to TYP I),and set the mechanism to the recording and pausing condition in advance. 2.After setting to the recording conditions, connect 1Mohm in series to the eraser head on the recording and playback mechanism side, and measure the eraser current from both of the eraser terminal.	TYP II :120mA TYP I :75mA	

Flow of functional operation until TOC read

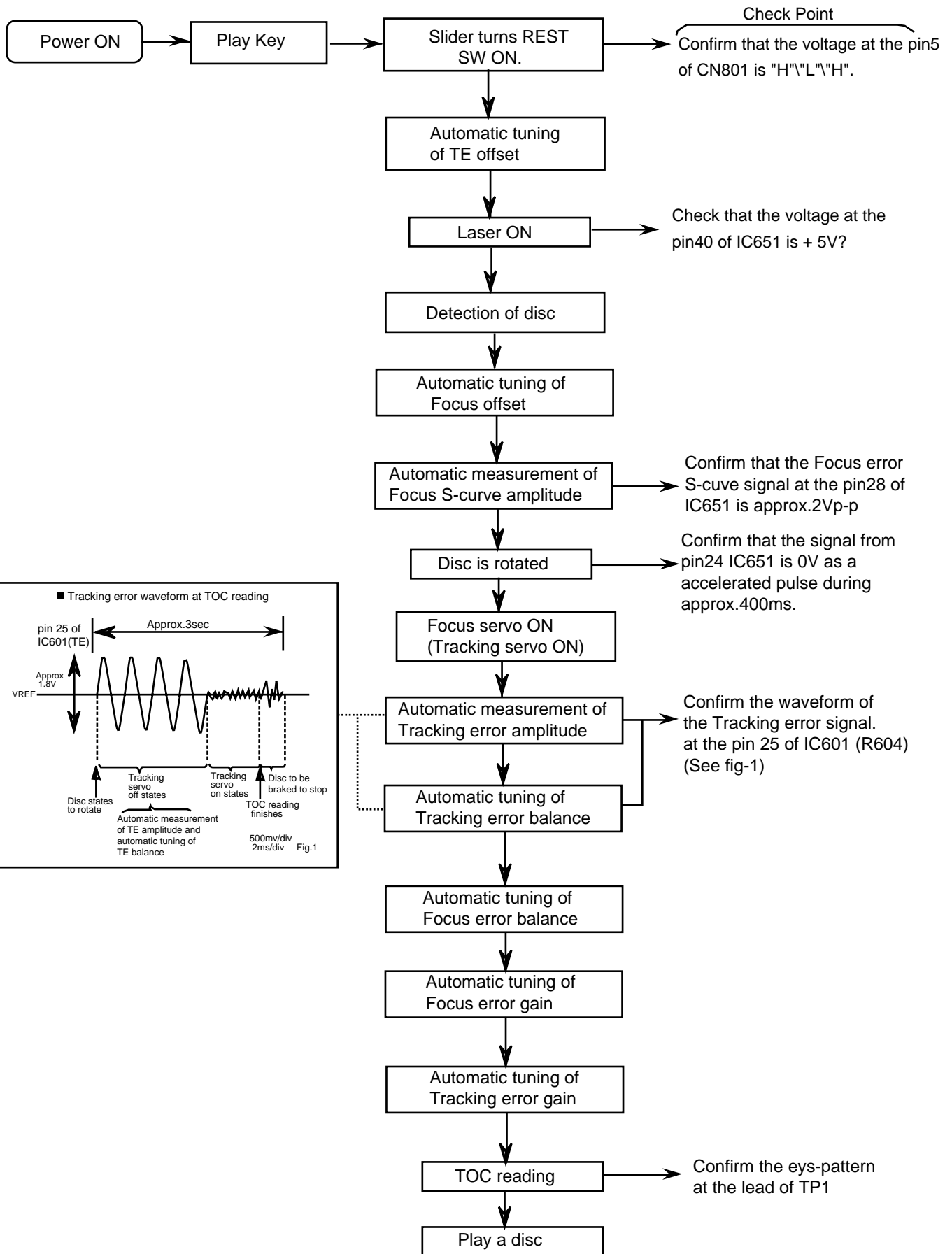

Maintenance of laser pickup

(1) Cleaning the pick up lens

Before you replace the pick up, please try to clean the lens with a alcohol soaked cotton swab.

(2) Life of the laser diode

When the life of the laser diode has expired, the following symptoms will appear.

1. The level of RF output (EFM output: amplitude of eye pattern) will below.

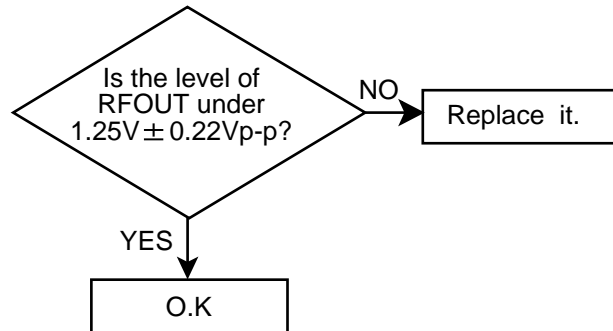

Replacement of laser pickup

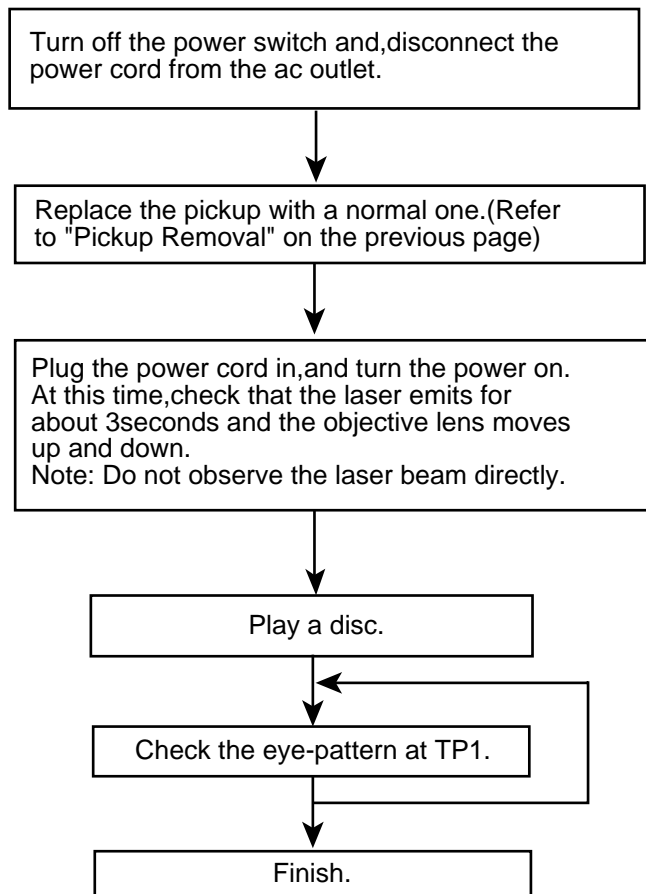

(3) Semi-fixed resistor on the APC PC board.

The semi-fixed resistor on the APC printed circuit board which is attached to the pickup is used to adjust the laser power.Since this adjustment should be performed to match the characteristics of the whole optical block, do not touch the semi-fixed resistor.

If the laser power is lower than the specified value,the laser diode is almost worn out, and the laser pickup should be replaced.

If the semi-fixed resistor would be adjusted when the pickup operates normally,the laser pickup may be damaged due to excessive current.

Description of major ICs

■ BA15218DIP (IC302,IC303,IC852) : OP AMP.

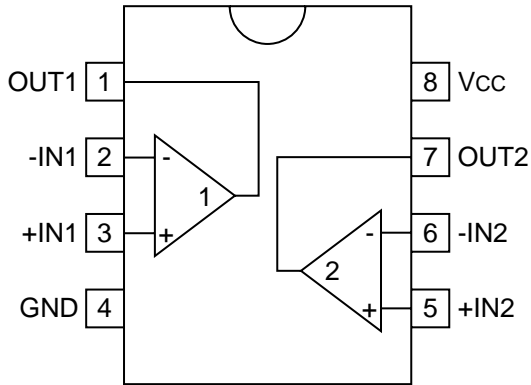

■ BA3126N (IC401) : R/P Switch

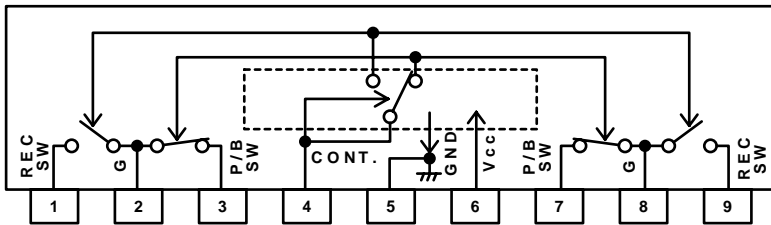

■ TA8409S (IC703,IC851,IC852) : Motor driver

1.Pin layout

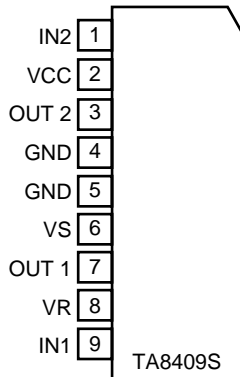

2.Pin function

INPUT		OUTPUT		MODE
IN1	IN2	OUT1	OUT2	MOTOR
0	0	∞	∞	STOP
1	0	H	L	CW/CCW
0	1	L	H	CCW/CW
1	1	L	L	BRAKE

■ AN8806SB-W (IC601) : RF&SERVO AMP

1.Pin layout

PD 1	36 PDAC
LD 2	35 PDBD
LDON 3	34 PDF
LDP 4	33 PDE
VCC 5	32 PDER
RF- 6	31 PDFR
RF OUT 7	30 TBAL
RF IN 8	29 FBAL
C.AGC 9	28 EF-
ARF 10	27 EF OUT
C.ENV 11	26 TE-
C.EA 12	25 TE OUT
CS BDO 13	24 CROSS
BDO 14	23 TE BPF
CS BRT 15	22 VDET
OFTR 16	21 LD OFF
/NRFDDET 17	20 VREF
GND 18	19 ENV

2.Block diagram

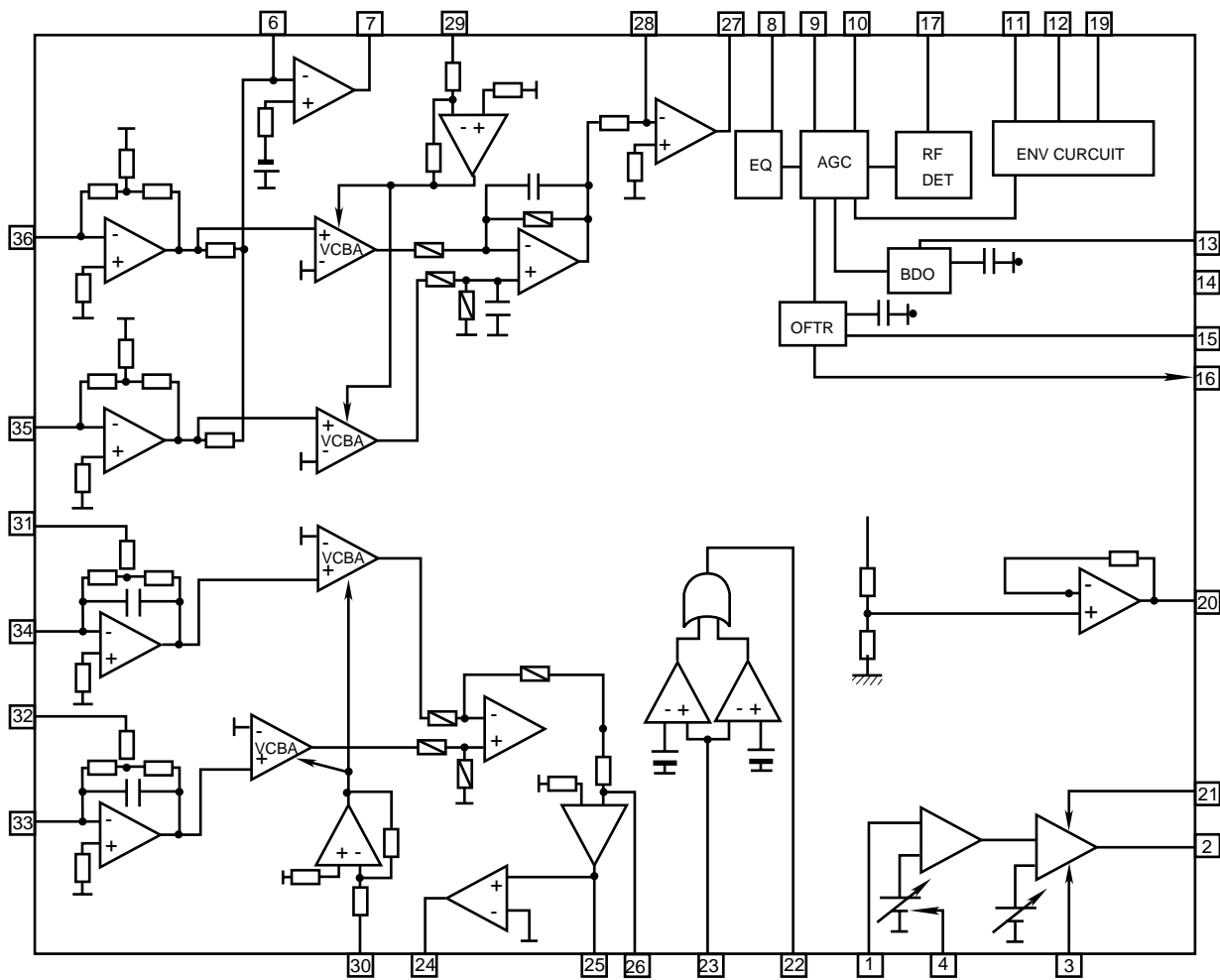

3. Pin function

Pin No.	symbol	I/O	Function
1	PD	I	APC amp . Input terminal
2	LD	O	APC amp . Output terminal
3	LD ON	I	LD ON/OFF control terminal
4	LDP	--	Connect to GND
5	VCC	--	Power supply
6	RF-	I	RF amp . Reversing input terminal
7	RF OUT	O	RFamp . Output terminal
8	RF IN	I	AGC input terminal
9	C.AGC	I/O	AGC loop filter connection terminal
10	ARF	O	ARF output terminal
11	C.ENV	I/O	RF detection capacity connection terminal
12	C.EA	I/O	HPF-amp capacity connection terminal
13	CS BDO	I/O	Capacity connection terminal for RF discernment side envelope detection
14	BDO	O	BDO output terminal
15	CS BRT	I/O	Capacity connection terminal for RF discernment side envelope detection
16	OFTR	O	OFTR output terminal
17	/NRFDET	O	RFDET output terminal
18	GND	--	Connect to GND
19	ENV	O	3TENV output terminal
20	VREF	O	VREF output terminal
21	LD OFF	--	APC OFF control terminal
22	VDET	O	VDET output terminal
23	TE BPF	I	VDET input terminal
24	CROSS	O	CROSS output terminal
25	TE OUT	O	TE amp . Output terminal
26	TE-	I	FE amp . Reversing input terminal
27	FE OUT	O	FE amp . output terminal
28	FE-	I	FE amp . Reversing input terminal
29	FBAL	I	F.BAL control terminal
30	TBAL	I	T.BAL control terminal
31	PDFR	I/O	I-V amp conversion resistance adjustment terminal
32	PDER	I/O	I-V amp conversion resistance adjustment terminal
33	PDF	I	I-V amp input terminal
34	PDE	I	I-V amp input terminal
35	PD BD	I	I-V amp input terminal
36	PD AC	I	I-V amp input terminal

■ BA3837 (IC351) : MIC Mixer

1. Block diagram

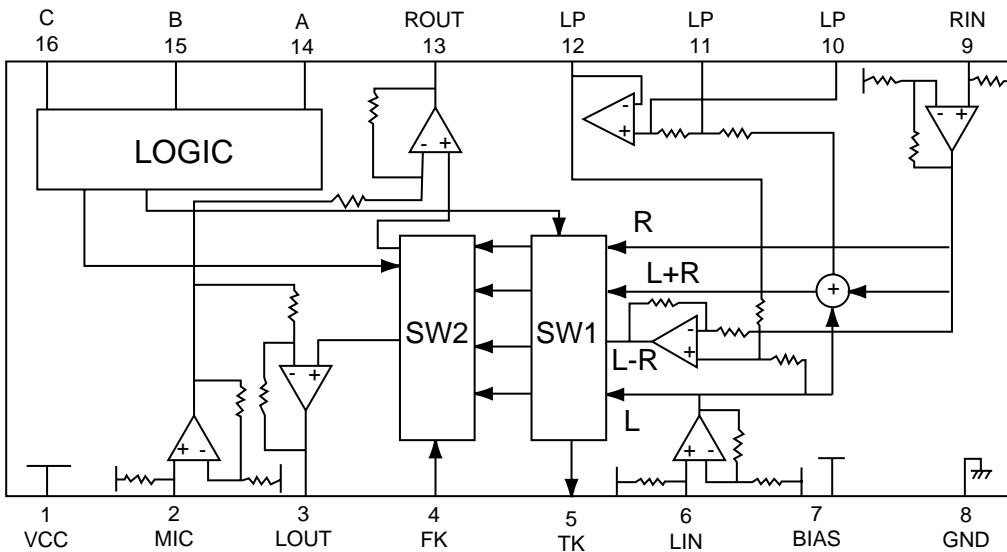

2. Pin function

Pin No.	Symbol	I/O	Description
1	VCC	-	Power supply
2	MIC IN	I	Microphone mixing input
3	LOUT	O	Channel L output
4	FK	-	Non connect
5	TK	-	Non connect
6	LIN	I	Channel L input
7	BIAS	I	Signal bias
8	GND	-	Connect to GND
9	RIN	I	Channel R input
10	LPF1	O	Connects to LPF time constant element
11	LPF2	O	Connects to LPF time constant element
12	LPF3	O	LPF output
13	ROUT	O	Channel R output
14	CONTA	I	Mode select input A
15	CONTB	I	Mode select input B
16	CONTC	I	Mode select input C

■ BA6897FP-W (IC801) : 4channel driver

1.Pin layout & Block diagram

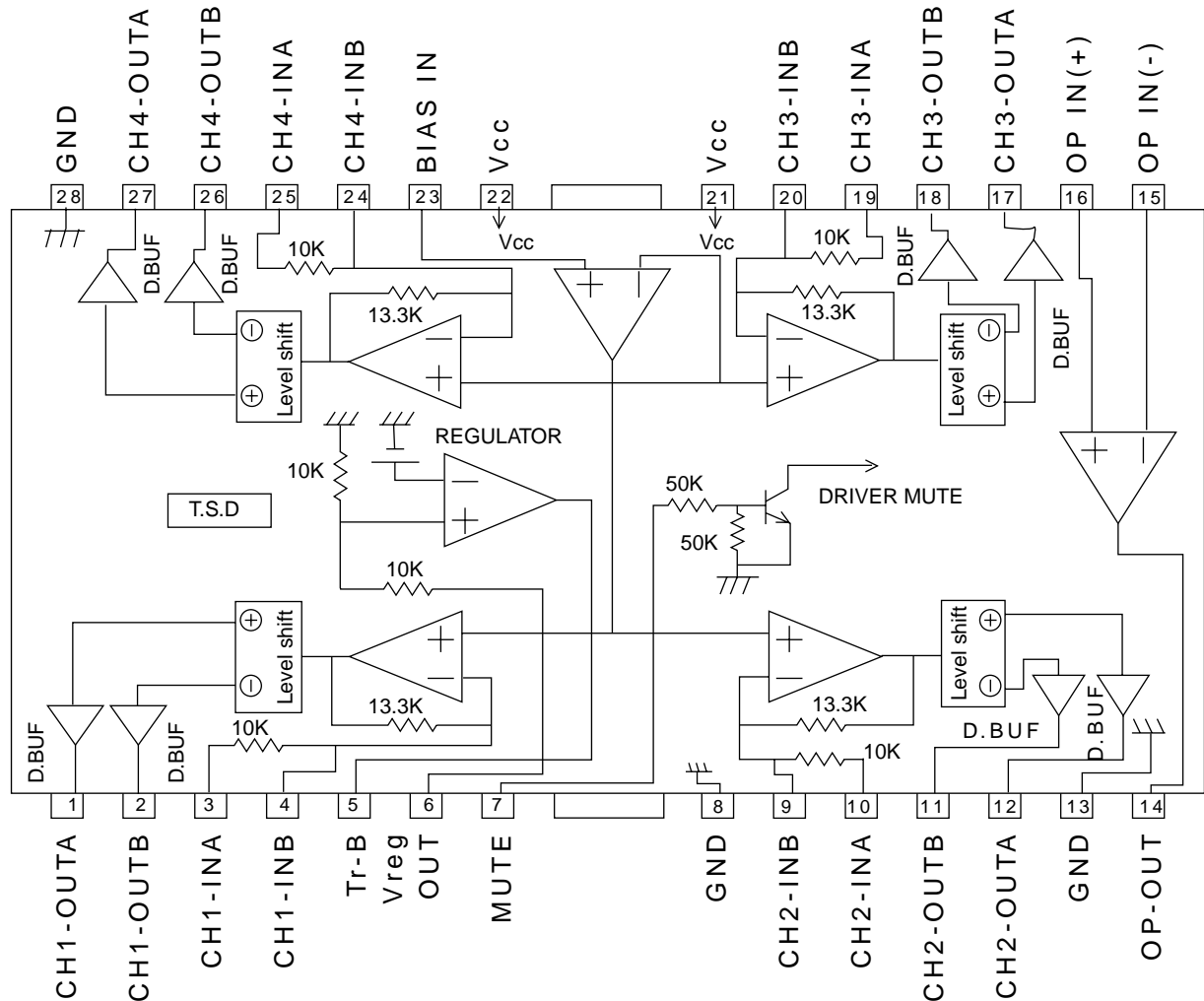

T.S.D;Thermal shutdown

D.BUF:Drive buffer

2.Pin function

Pin NO.	Symbol	Function	Pin NO.	Symbol	Function
1	CH1-OUTA	Driver CH1 - output	15	OP IN(-)	Operation amplifier - input
2	CH1-OUTB	Driver CH1 + output	16	OP IN(+)	Operation amplifier + output
3	CH1-INA	Driver CH1 input	17	CH3-OUTA	Driver CH3 - output
4	CH1-INB	Driver CH1 gain adjustment Input terminal	18	CH3-OUTB	Driver CH3 + output
5	Tr-B	Connect to the base of external Tr	19	CH3-INA	Driver CH3 input
6	Vreg OUT	Fixed voltage output	20	CH3-INB	Driver CH3 gain adjustment Input terminal
7	MUTE	Mute control terminal	21	Vcc	Power supply terminal
8	GND	GND	22	Vcc	Power supply terminal
9	CH2-INB	Driver CH2 gain adjustment Input terminal	23	BAIS IN	Bias amplifier input terminal
10	CH2-INA	Driver CH2 input	24	CH4-INB	Driver CH4 gain adjustment Input terminal
11	CH2-OUTB	Driver CH2 + output	25	CH4-INA	Driver CH4 input
12	CH2-OUTA	Driver CH2 - output	26	CH4-OUTB	Driver CH4 + output
13	GND	Sub-slate GND	27	CH4-OUTA	Driver CH4 - output
14	OPOUT	Operation amplifier output	28	GND	Sub-slate GND

■ BU9253FS (IC851) : LPF&ECHO MIX.

1.Pin layout & block diagram

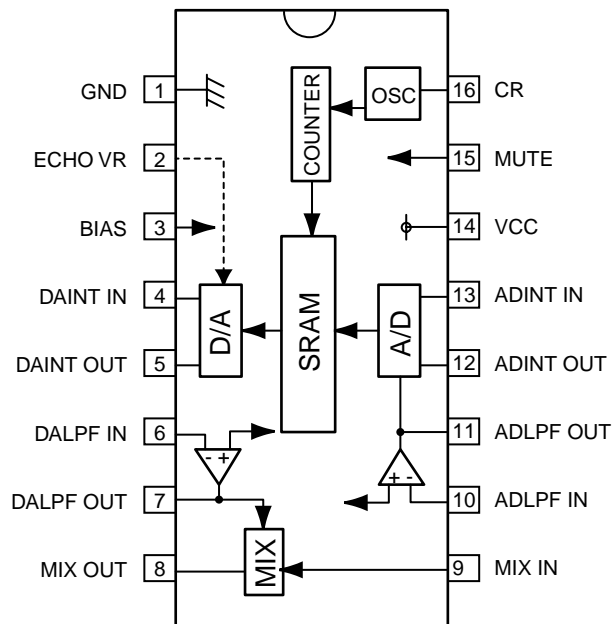

2.Pin function

Pin No.	Symbol	I/O	Descriptions
1	GND	-	Connect GND
2	ECHO VR	I	Echo level control
3	BIAS	-	Analog part DC bias
4	DAINT OUT	I	DA side integrator output
5	DAINT IN	O	DA side integrator input
6	DALPF IN	I	DA side LPF input
7	DALPF OUT	O	DA side LPF output
8	MIX OUT	O	Mix AMP output for original tone& echo tone
9	MIX IN	I	Mix AMP input pin for original tone
10	ADLPF IN	I	AD side LPF input
11	ADLPF OUT	O	AD side LPF output
12	ADINT OUT	O	AD side integrator output
13	ADINT IN	I	AD side integrator input
14	VCC	-	Power supply
15	MUTE	I	Mute control signal input
16	CR	-	CR pin for oscillator

■ LC72136N (IC2) : PLL Frequency Synthesizer

1. Pin layout

XT	1	22	$\overline{\text{XT}}$
FM/AM	2	21	GND
CE	3	20	LPFOUT
DI	4	19	LPFIN
CLOCK	5	18	PD
DO	6	17	VCC
FM/ST/VCO	7	16	FMIN
AM/FM	8	15	AMIN
	9	14	
SDIN	10	13	IFCONT
	11	12	IFIN

2. Block diagram

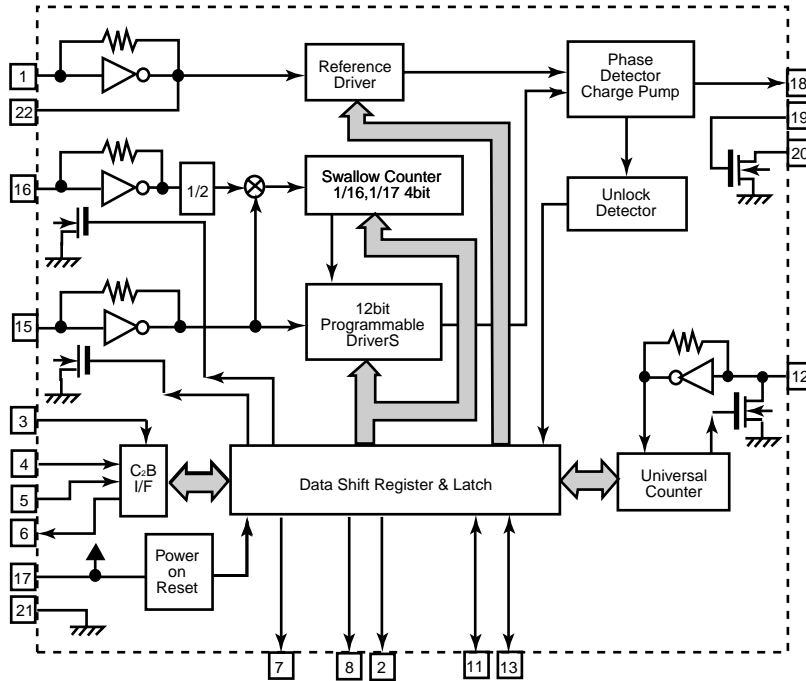

3. Pin function

Pin No.	Symbol	I/O	Function	Pin No.	Symbol	I/O	Function
1	XT	I	X'tal oscillator connect (75kHz)	12	IFIN	I	IF counter signal input
2	$\overline{\text{FM/AM}}$	O	LOW:FM mode	13	IFCONT	O	IF signal output
3	CE	I	When data output/input for 4pin(input) and 6pin(output): H	14		-	Not use
4	DI	I	Input for receive the serial data from controller	15	AMIN	I	AM Local OSC signal output
5	CLOCK	I	Sync signal input use	16	FMIN	I	FM Local OSC signal input
6	DO	O	Data output for Controller Output port	17	VCC	-	Power suply(VDD=4.5-5.5V) When power ON:Reset circuit move
7	FM/ST/VCO	O	"Low": MW mode	18	PD	O	PLL charge pump output(H: Local OSC frequency Height than Reference frequency. L: Low Agreement: Height impedance)
8	$\overline{\text{AM/FM}}$	O	Open state after the power on reset	19	LPFIN	I	Input for active lowpassfilter of PLL
9	LW	I/O	Input/output port	20	LPFOUT	O	Output for active lowpassfilter of PLL
10	MW	I/O	Input/output port	21	GND	-	Connected to GND
11	SDIN	I/O	Data input/output	22	$\overline{\text{XT}}$	I	X'tal oscillator(75KHz)

■ MN35510 (IC651) : DIGITAL SERVO&DIGITAL SIGNAL PROCESSER

1. Terminal Layout

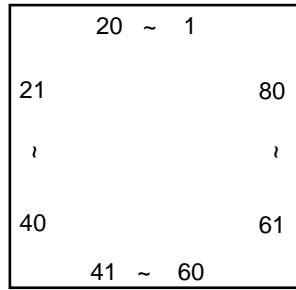

2. Block Diagram

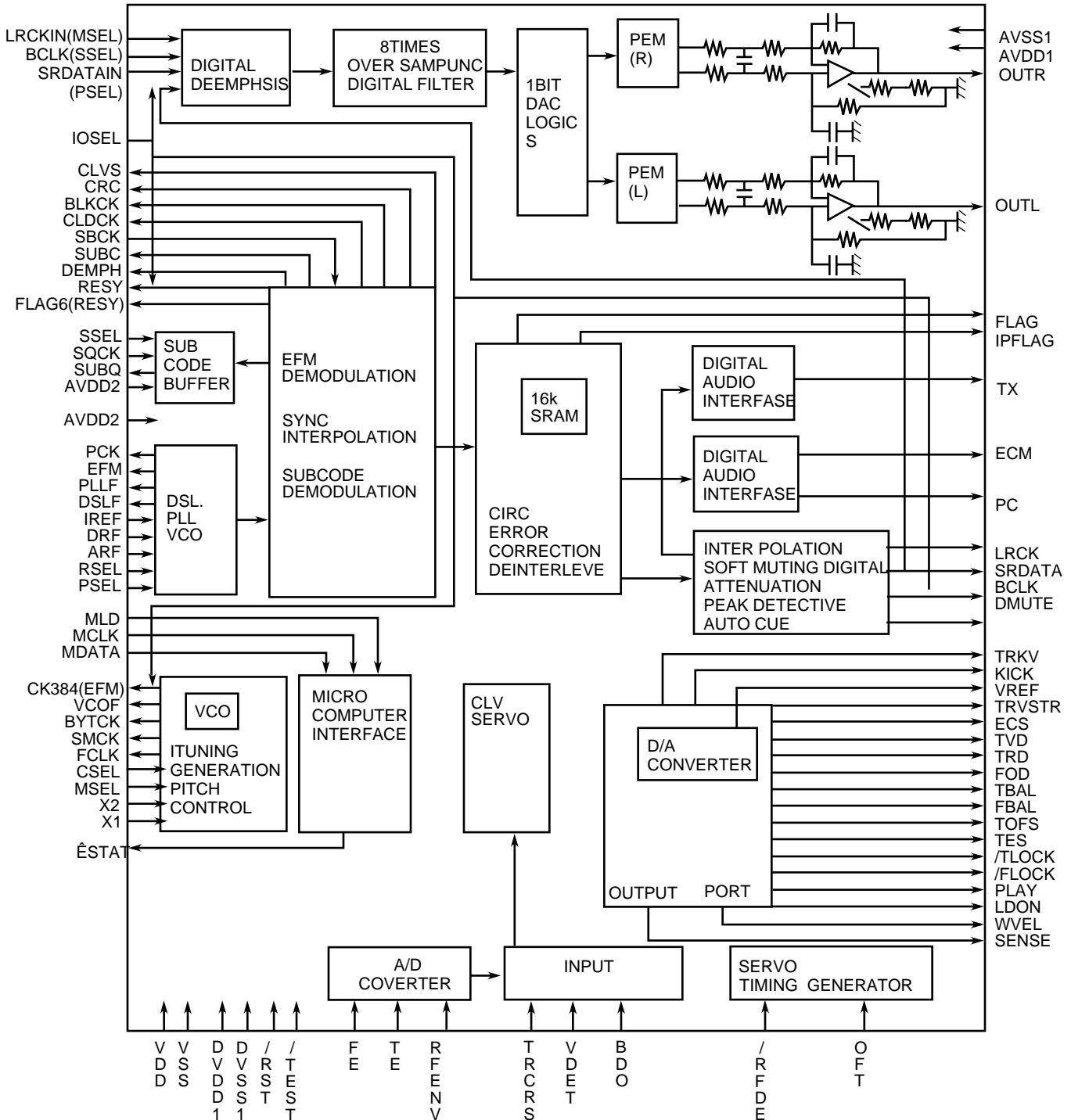

3. Description

Pin No.	symbol	I/O	Description	Pin No.	symbol	I/O	Description
1	BCLK	O	Not used	41	TES	O	Tracking error shunt signal output(H:shunt)
2	LRCK	O	Not used	42	PLAY	—	Not used
3	SRDATA	O	Not used	43	WVEL	—	Not used
4	DVDD1	—	Power supply (Digital)	44	ARF	I	RF signal input
5	DVSS1	—	Connected to GND	45	IREF	I	Reference current input pin
6	TX	O	Digital audio interface output	46	DRF	I	Bias pin for DSL
7	MCLK	I	μ com command clock signal input (Data is latched at signal's rising point)	47	DSL F	I/O	Loop filter pin for DSL
8	M DATA	I	μ com command data input	48	PLL F	I/O	Loop filter pin for PLL
9	MLD	I	μ com command load signal input	49	VCOF	—	Not used
10	SENSE	O	Not used	50	AVDD2	—	Power supply(Analog)
11	FLOCK	O	Not used	51	AVSS2	—	Connected to GND(Analog)
12	TLOCK	O	Not used	52	EFM	—	Not used
13	BLKCK	O	sub-code block clock signal output	53	PCK	—	Not used
14	SQCK	I	Outside clock for sub-code Q resistor input	54	PDO	—	Not used
15	SUBQ	O	Sub-code Q -code output	55	SUBC	—	Not used
16	DMUTE	—	Connected to GND	56	SBCK	—	Not used
17	STATUS	O	Status signal (CRC,CUE,CLVS,TTSTOP,ECLV,SQOK)	57	VSS	—	Connected to GND(for X'tal oscillation circuit)
18	RST	I	Reset signal input (L:Reset)	58	XI	I	Input of 16.9344MHz X'tal oscillation circuit
19	SMCK	—	Not used	59	X2	O	Output of X'tal oscillation circuit
20	PMCK	—	Not used	60	VDD	—	Power supply(for X'tal oscillation circuit)
21	TRV	O	Traverse enforced output	61	BYTCK	—	Not used
22	TVD	O	Traverse drive output	62	CLDCK	—	Not used
23	PC	—	Not used	63	FCLK	—	Not used
24	ECM	O	Spindle motor drive signal (Enforced mode output) 3-State	64	IPPLAG	—	Not used
25	ECS	O	Spindle motor drive signal (Servo error signal output)	65	FLAG	—	Not used
26	KICK	O	Kick pulse output	66	CLVS	—	Not used
27	TRD	O	Tracking drive output	67	CRC	—	Not used
28	FOD	O	Focus drive output	68	DEMPH	—	Not used
29	VREF	I	Reference voltage input pin for D/A output block (TVD,FOD,FBA,TBAL)	69	RESY	—	Not used
30	FBAL	O	Focus Balance adjust signal output	70	IOSEL	—	pull up
31	TBAL	O	Tracking Balance adjust signal output	71	TEST	—	pull up
32	FE	I	Focus error signal input(Analog input)	72	AVDD1	—	Power supply(Digital)
33	TE	I	Tracking error signal input(Analog input)	73	OUT L	O	Lch audio output
34	RF ENV	I	RF envelope signal input(Analog input)	74	AVSS1	—	Connected to GND
35	VDET	I	Vibration detect signal input(H:detect)	75	OUT R	O	Rch audio output
36	OFT	I	Off track signal input(H:off track)	76	RSEL	—	pull up
37	TRCRS	I	Track cross signal input	77	CSEL	—	Connected to GND
38	RFDET	I	RF detect signal input(L:detect)	78	PSEL	—	Connected to GND
39	BDO	I	BDO input pin(L:detect)	79	MSEL	—	Connected to GND
40	LDON	O	Laser ON signal output(H:on)	80	SSEL	—	Pull up

■ TDA7442D (IC301) : Souse select

1. PIN CONNECTION

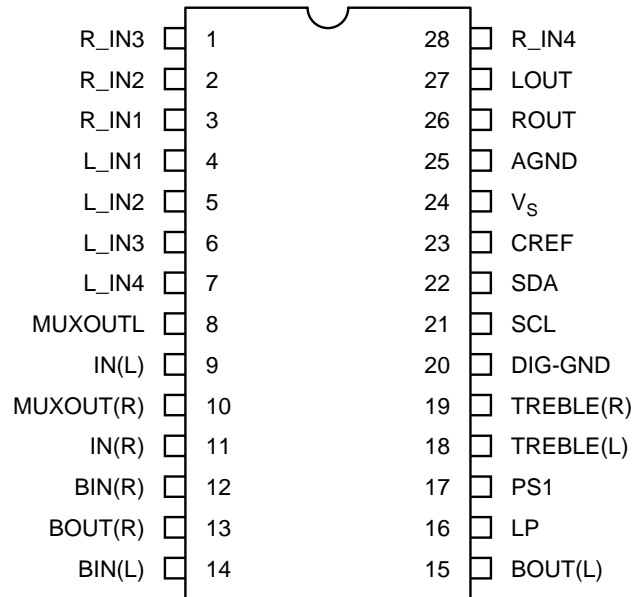

2. BLOCK DIAGRAM

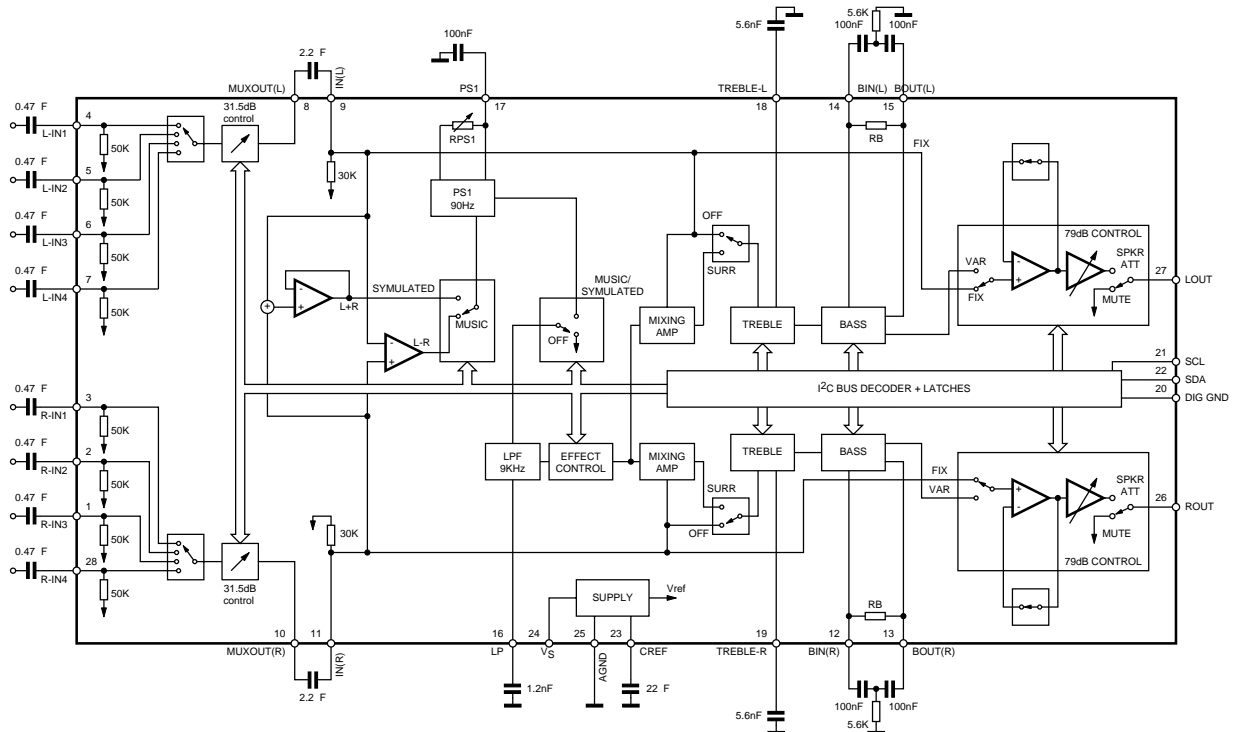

■ UPD78055GCA37 (IC251) : CD Changer control

1. Terminal Layout

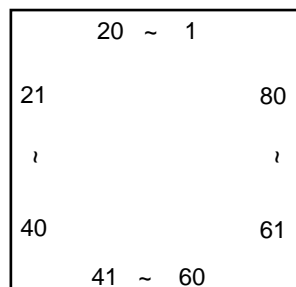

2. Pin function

Pin No.	symbol	I/O	Description	Pin No.	Symbol	I/O	Description
1	DEMPH	I	Deemphasis input	41	LM DOWN	O	L CAM down
2	DEMPHO	O	Deemphasis output	42	RM UP	O	R CAM up
3	OS OFF	I	On screen display on/off	43	RMDOWN	O	R CAM down
4	AVSS	-	Connected to GND	44	CHECK	I	Not used
5	MCS	I	Mode control select	45	CHECK1	I	Not used
6	MRDY	I	SUB Ready	46	CHECK2	I	Not used
7	AVREF1	-	AV reference	47	CHECK3	I	Not used
8	KCMND		SVC3 Serial data out put	48~59			connected to GND
9	MSTAT	O	SVC3 Status input input	60	RESET	I	VC3 reset out
10	KCLK	I	SVC3 Serial clock input	61	STAT	I	Statues signal
11	SUB	I	Sub-code Q code output	62	HREG	O	Not used
12	RST	O	Reset signal input (L : Reset)	63	HRDY	I	Not used
13	SQCK	I	Outside clock for sub-code Q resister input	64	DRMUTE	O	BTL Driver mute
14	DMUTE	I	Digital mute	65	MCLK	I	μ com command clock signal input
15	MREQ	O	Not used	66	MDATA	I	μ com command data input
16	VCDEMP	-	Not used	67	MLD	I	μ com command lode signal input
17	SRDATA	-	Not used	68	VDD	-	Power supply (for X' tal Q oscillation circuit)
18	SRCLK	-	Not used	69	X2	O	Out of X' tal oscillation circuit
19~26	CAM0~7	I	CAM SW input	70	X1	I	Input of 16.9344MHz X' tal oscillation circuit
27~29	1~3SSW	I	Sub tray SW input	71	IC	-	connected to GND
30~32	3~1MSW	I	Sub tray SW output	72	XT2	-	Not used
33	VSS	-	Connected to GND	73	REST	I	Rest SW input
34	DISC	I	Disk sensor	74	AVDD	-	A/D converter power supply
35	SHIFT	I	Test mode(Not used)	75	AVREF	-	Digital GND
36	MNT	I	Test mode(Not used)	76	SSEL	-	Not used
37	MNT1	I	Test mode(Not used)	77	MSEL	-	Not used
38	MNT2	I	Test mode(Not used)	78	PSEL	-	Not used
39	VCORST	-	Not used	79	IOSEL	O	Data select out
40	LMUP	O	L CAM up	80	P ON	O	Power ON/OFF

JVC

VICTOR COMPANY OF JAPAN, LIMITED
AUDIO & COMMUNICATION BUSINESS DIVISION
PERSONAL & MOBILE NETWORK B.U. 10-1,1Chome,Ohwatari-machi,Maebashi-city,371-8543,Japan